

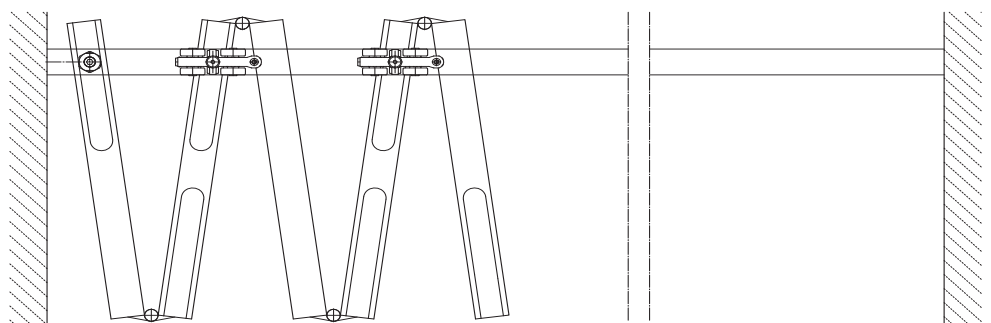

KIT PER PORTE LEGNO PIEGHEVOLI a LIBRO o a SOFFIETTO - MONTAGGIO Frontale a BAIONETTA

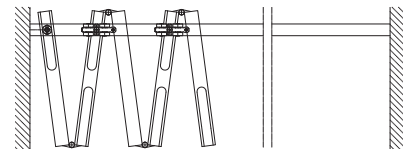



**PUMA.5300 per 2, 3, 4, 5 PORTE LEGNO LIBRO - Sistema con MONTAGGIO Frontale a BAIONETTA**

Sistema pratico di montaggio e regolazione a Baionetta, ricavato da estrusi in alluminio.

Nei KIT sono compresi i Carrelli di scorrimento, per una eventuale alternativa di questi, andare a pag.18 e 19.

- Spessore Porte : da 30 a 55 mm compresi.
- Larghezza minima Porta : 400\* mm (con "C" + "E") | \*( Senza "E", Larghezza minima Porta = 210 mm ).
- Larghezza massima Porta consigliata : 900 mm

# Versione Standard.

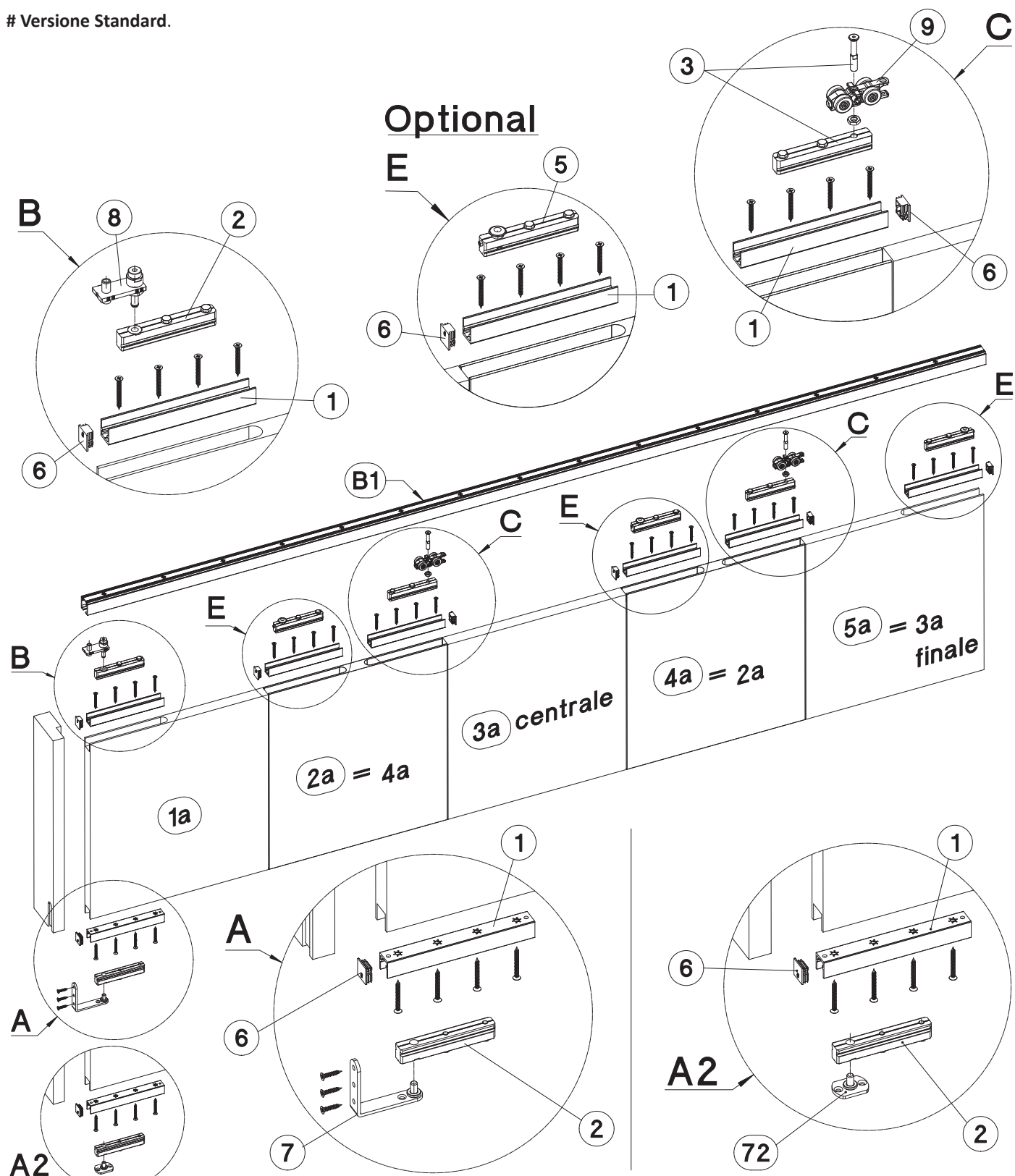



Dettaglio COMPONENTI:

Riferim.	Immagine	Codice Identificativo <u>referito a NR.1 Pz o Kit</u> (salvo diversa indicazione)																														
(1)		Parte Fissa Baionetta L = 186 mm. Alluminio estruso, finitura Naturale. Completo di fori svasati per il fissaggio. # Codice: <b>PUMA . 5302</b>																														
(2)		Parte Maschio Baionetta con Bussola Foro $\varnothing$ 8 mm. Alluminio estruso, finitura Naturale. Completo di due Viti TE M6 per il bloccaggio in posizione. # Codice: <b>PUMA . 5334 . K</b>																														
(3)		Parte Maschio Baionetta con Filetto Femmina M8. Alluminio estruso, finitura Naturale. Completo di: NR.2 Viti TE M6 per il bloccaggio in posizione e NR.1 Vite M8 per il collegamento al Carrello (9). # Codice: <b>PUMA . 5332 . K</b>																														
(5)		<b>OPTIONAL:</b> Parte Maschio Baionetta con Fermo molleggiato M14. Alluminio estruso, finitura Naturale. Completo di: NR.2 Viti TE M6 per il bloccaggio in posizione e NR.1 perno molleggiato M14 uso Fermo sotto il binario (B1) . # Codice: <b>PUMA . 5338 . K</b>																														
(6)		Tappo di chiusura di testa fresata frontale Porta per (1). Plastica morbida, diversi colori # Codice: <b>PUMA . 5932</b>																														
(7)		VERSIONE (A): Fulcro Fisso Inferiore a "L" - DX/SX con Perno $\varnothing$ 8 mm. Per fissaggio retro telaio. Acciaio. # Codice: <b>PUMA . 8030</b>																														
(72)		VERSIONE (A2): Fulcro Fisso Inferiore "Piatto", con Perno $\varnothing$ 8 mm. Per fissaggio al Pavimento. Acciaio. # Codice: <b>PUMA . 8032</b>																														
(8)		Fulcro Superiore DX/SX con Perno $\varnothing$ 8 mm. Posizione Regolabile. Acciaio. # Codice: <b>PUMA . 8180</b>																														
(9)		Carrello <b>Dragon Kg 140</b> (riferito a nr. 2 Carrelli) Corpo in Tecnopolimero DRAGON (esclusivo materiale SLIDING). Con nr.4 Cuscinetti rettificati a carrello, rivestiti in Delrin. # Codice: <b>PUMA . 6 . 2140</b>																														
(B1)		<table border="1"> <thead> <tr> <th>Binario singolo Max.240 Kg</th> <th>L [mm]</th> <th>Anodizzato Argento</th> </tr> </thead> <tbody> <tr> <td>Foratura a passo (150 mm)</td> <td>2000</td> <td>PUMA . 0101 . 2000 . A</td> </tr> <tr> <td>Foratura a passo (150 mm)</td> <td>2500</td> <td>PUMA . 0101 . 2500 . A</td> </tr> <tr> <td>Foratura a passo (150 mm)</td> <td>3000</td> <td>PUMA . 0101 . 3000 . A</td> </tr> <tr> <td>Foratura a passo (150 mm)</td> <td>6000</td> <td>PUMA . 0101 . 6000 . A</td> </tr> <tr> <th>Binario singolo Max.120 Kg</th> <th>L [mm]</th> <th>Alluminio Naturale</th> </tr> <tr> <td>Foratura a passo (150 mm)</td> <td>2000</td> <td>PUMA . 0151 . 2000 . Z</td> </tr> <tr> <td>Foratura a passo (150 mm)</td> <td>2500</td> <td>PUMA . 0151 . 2500 . Z</td> </tr> <tr> <td>Foratura a passo (150 mm)</td> <td>3000</td> <td>PUMA . 0151 . 3000 . Z</td> </tr> <tr> <td>Foratura a passo (150 mm)</td> <td>6000</td> <td>PUMA . 0151 . 6000 . Z</td> </tr> </tbody> </table>	Binario singolo Max.240 Kg	L [mm]	Anodizzato Argento	Foratura a passo (150 mm)	2000	PUMA . 0101 . 2000 . A	Foratura a passo (150 mm)	2500	PUMA . 0101 . 2500 . A	Foratura a passo (150 mm)	3000	PUMA . 0101 . 3000 . A	Foratura a passo (150 mm)	6000	PUMA . 0101 . 6000 . A	Binario singolo Max.120 Kg	L [mm]	Alluminio Naturale	Foratura a passo (150 mm)	2000	PUMA . 0151 . 2000 . Z	Foratura a passo (150 mm)	2500	PUMA . 0151 . 2500 . Z	Foratura a passo (150 mm)	3000	PUMA . 0151 . 3000 . Z	Foratura a passo (150 mm)	6000	PUMA . 0151 . 6000 . Z
Binario singolo Max.240 Kg	L [mm]	Anodizzato Argento																														
Foratura a passo (150 mm)	2000	PUMA . 0101 . 2000 . A																														
Foratura a passo (150 mm)	2500	PUMA . 0101 . 2500 . A																														
Foratura a passo (150 mm)	3000	PUMA . 0101 . 3000 . A																														
Foratura a passo (150 mm)	6000	PUMA . 0101 . 6000 . A																														
Binario singolo Max.120 Kg	L [mm]	Alluminio Naturale																														
Foratura a passo (150 mm)	2000	PUMA . 0151 . 2000 . Z																														
Foratura a passo (150 mm)	2500	PUMA . 0151 . 2500 . Z																														
Foratura a passo (150 mm)	3000	PUMA . 0151 . 3000 . Z																														
Foratura a passo (150 mm)	6000	PUMA . 0151 . 6000 . Z																														

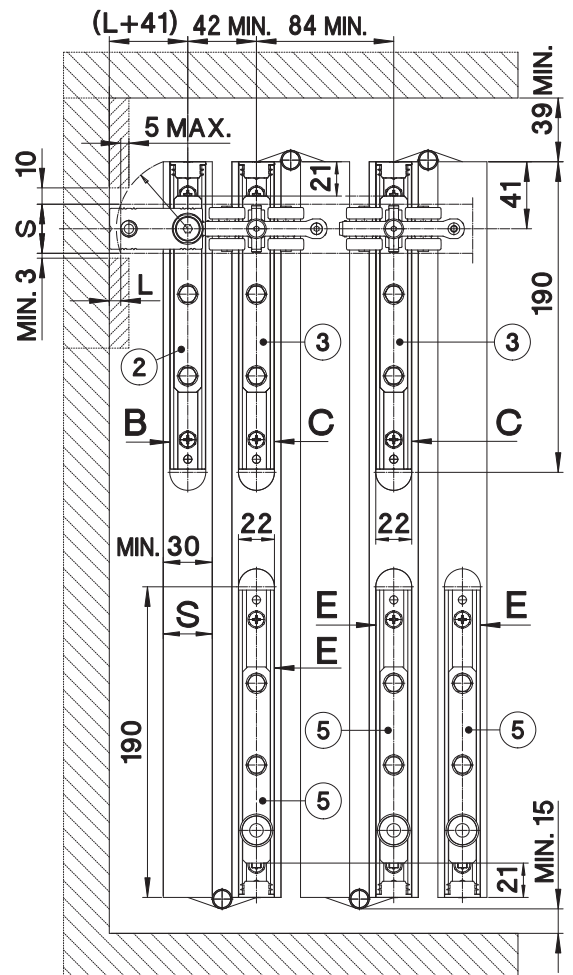
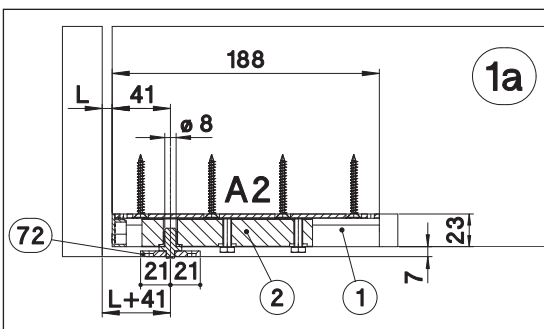
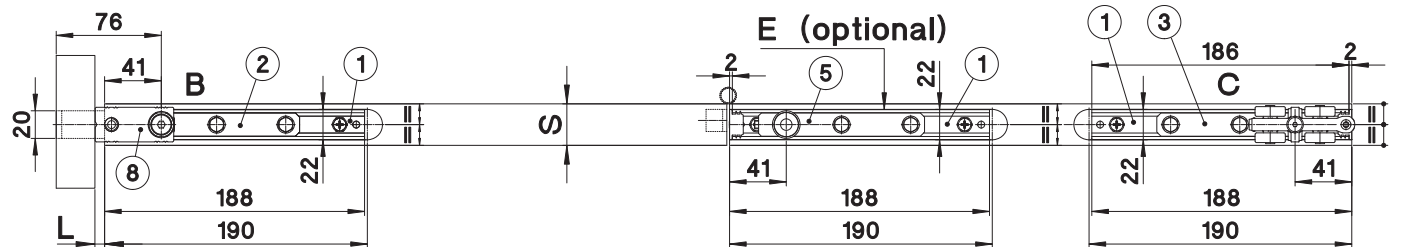
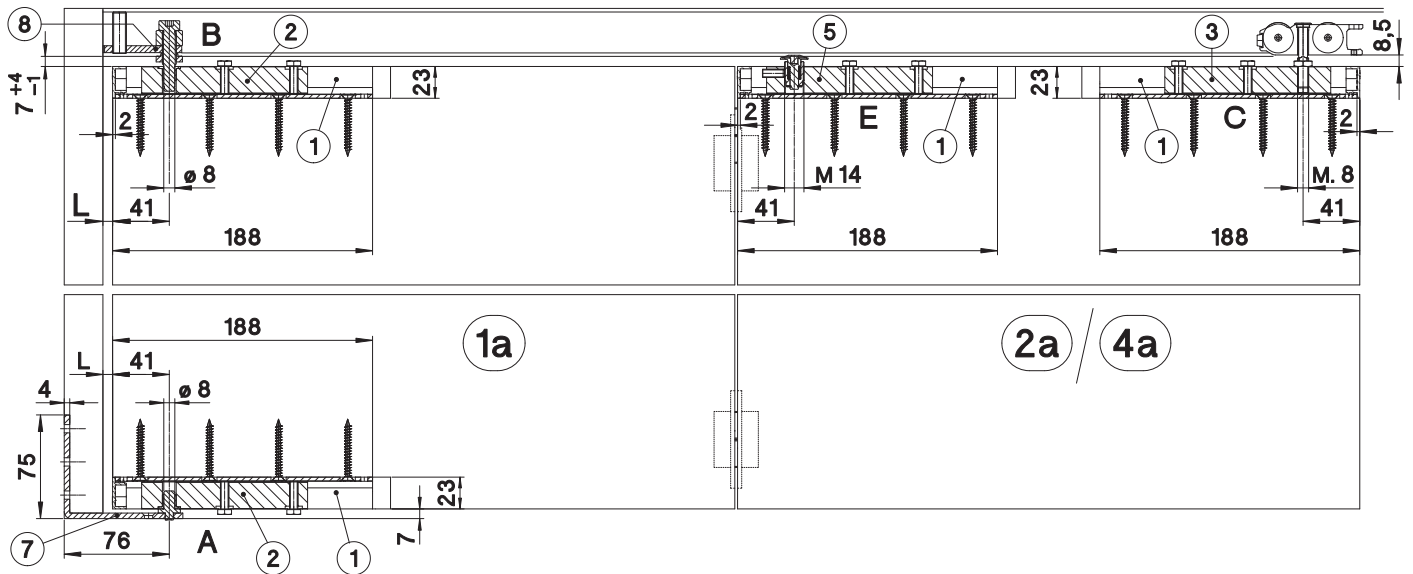

LEGENDA FORMULE / SCHEMI :

LA	= Larghezza Porta (Anta).
LV	= Larghezza Vano.
HA	= Altezza Porta (Anta).
HV	= Altezza Vano.
HP	= Altezza Passaggio.
NA	= Numero Porte (Ante).
1a...	= Porta (Anta) n° 1,2,3,4,5
L	= Luce Fuga.
S	= Spessore Porta (Anta).

Spessore Porta (S)	Luce Fuga (L)
Da 30 a 46 mm	7 mm
Da 47 a 50 mm	8 mm
Da 51 a 55 mm	9 mm

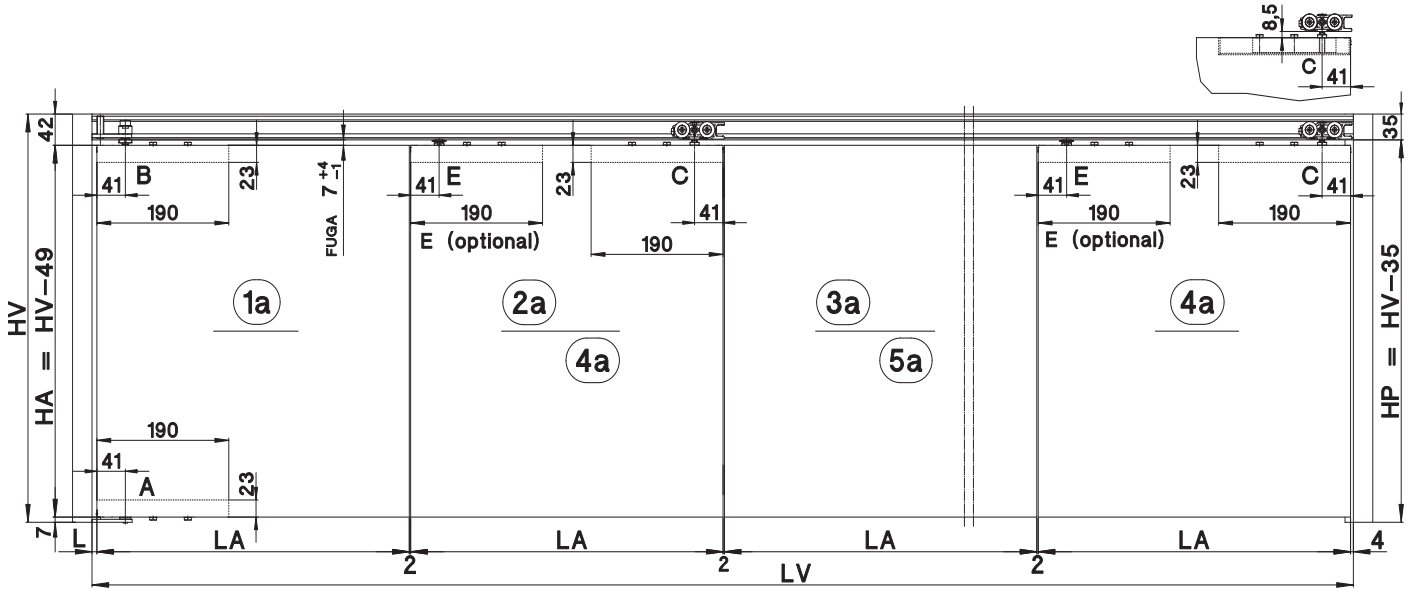
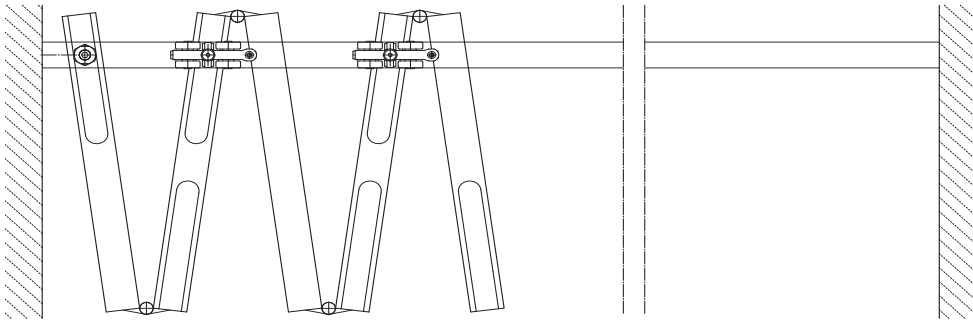

**Con Binario esterno a vista.**  
 Per Binario Incassato e per Carton Gesso, vedere schemi nelle pagine seguenti, dopo le Tabelle dei KIT.

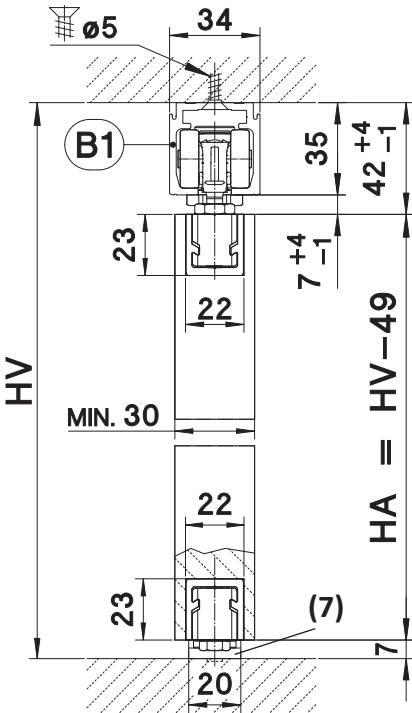

LEGENDA FORMULE / SCHEMI :

LA	= Larghezza Porta (Anta).
LV	= Larghezza Vano.
HA	= Altezza Porta (Anta).
HV	= Altezza Vano.
HP	= Altezza Passaggio.
NA	= Numero Porte (Ante).
1a...	= Porta (Anta) n° 1,2,3,4,5
L	= Luce Fuga.
S	= Spessore Porta (Anta).

Spessore Porta (S)	Luce Fuga (L)
Da 30 a 46 mm	7 mm
Da 47 a 50 mm	8 mm
Da 51 a 55 mm	9 mm

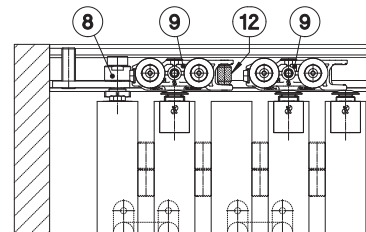
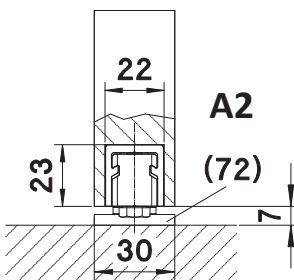

**(12)** Fermo da aggiungere in testa al primo Carrello (9) in caso di 4 o 5 Porte.  
 # PUMA. 2590

Imputare i dati nella tabella per poi calcolare LA e HA.

LV =	
L =	
NA =	
HV =	

LA =	$\frac{[ LV - (L+4) ] - [ 2 \times (NA-1) ]}{NA}$	
HA =	HV - 49	



Esempi di composizioni

SX

DX

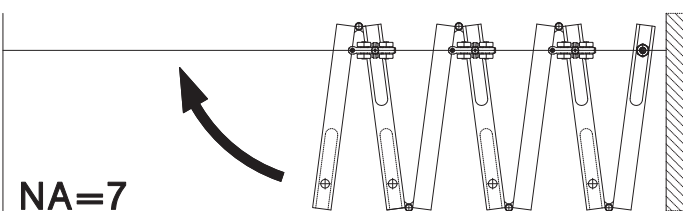
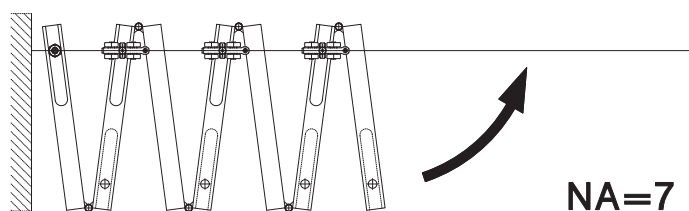
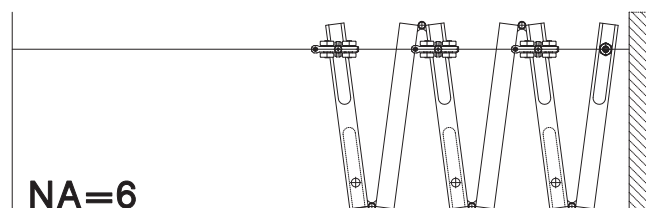
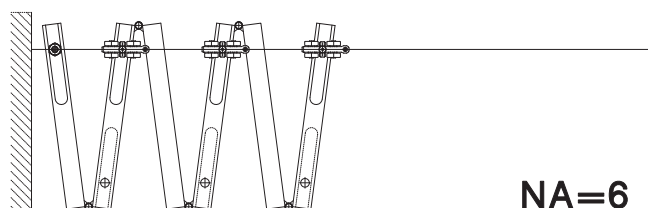
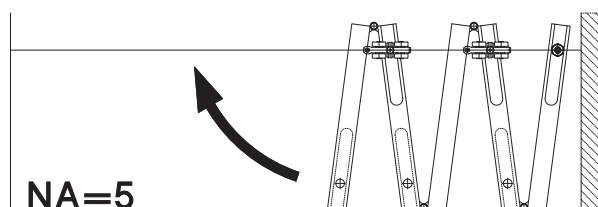
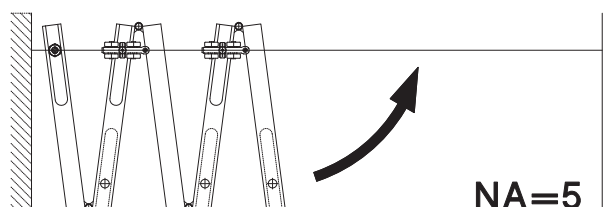
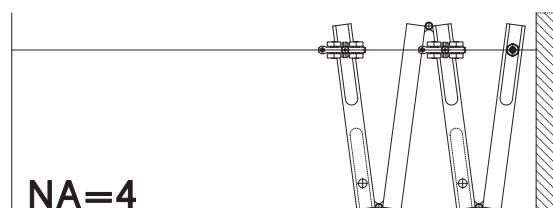
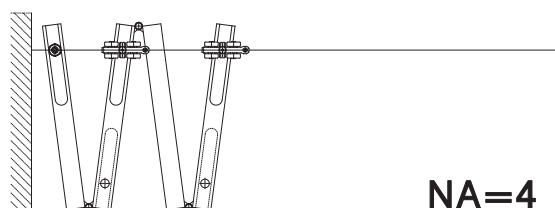
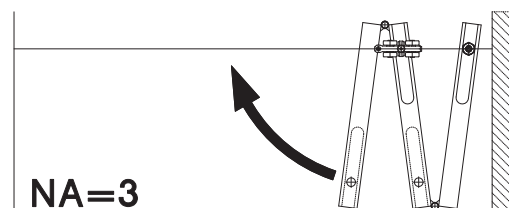
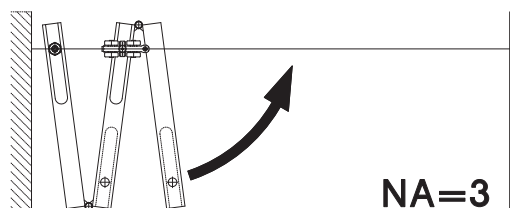
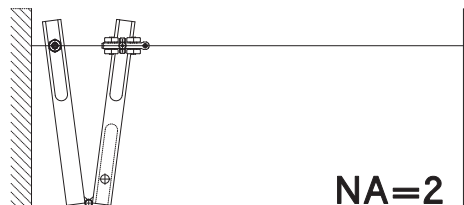

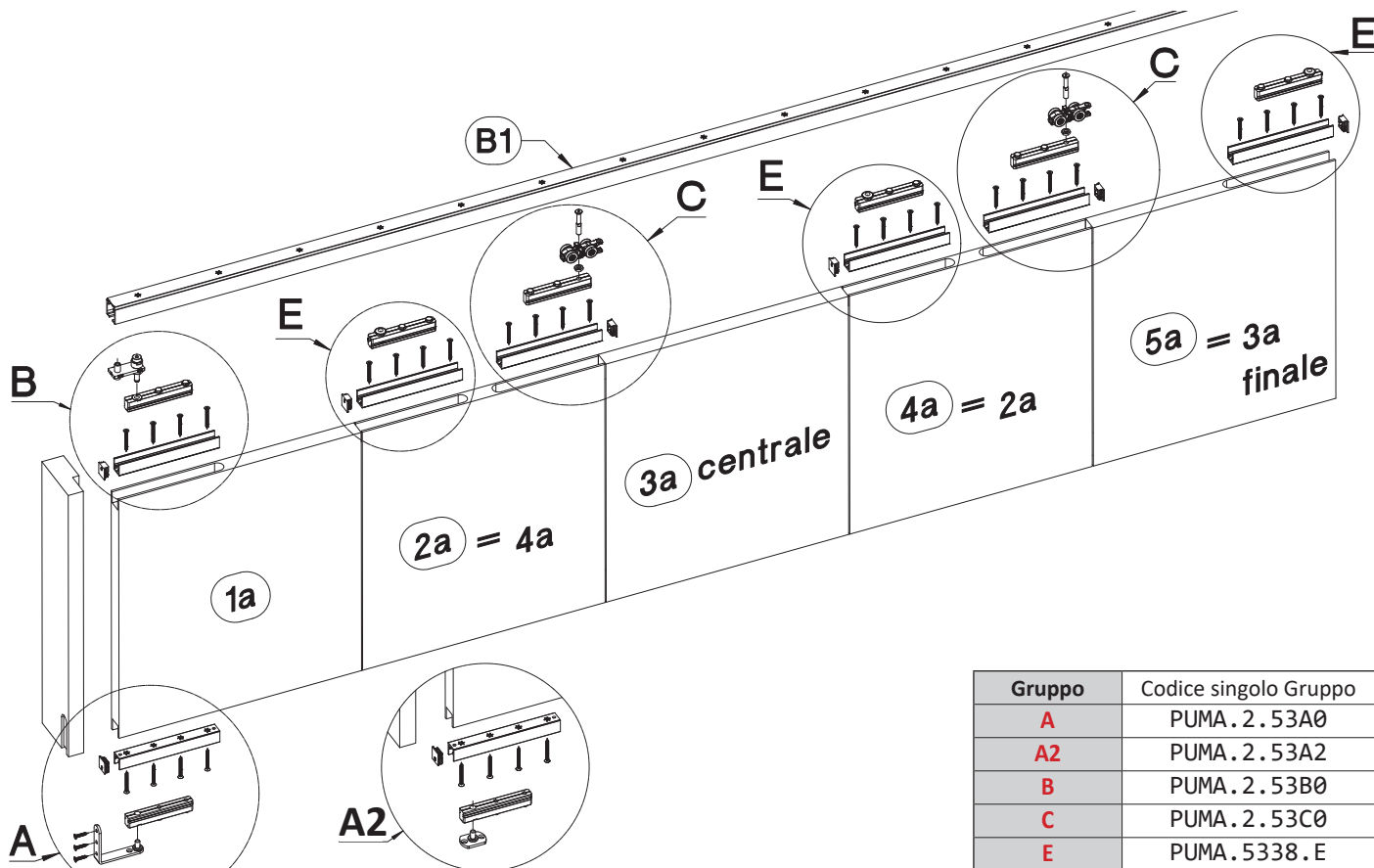

Con Fulcro Inferiore a "L" : **A**



TABELLA KIT "PUMA.5300" SX o DX, con Fulcro Inferiore "A", con riferim. q.tà gruppi:

**OPTIONAL :**  
PUMA.5338.E

NA	RIF. KIT	Codice KIT	Rif.	Q.tà	Rif.	Q.tà	Rif.	Q.tà	Rif.	Q.tà
2	SX o DX	PUMA.1.5300.2030.N	(A)	1	(B)	1	(C)	1	(E)	1
3	SX o DX	PUMA.1.5300.2030.N	(A)	1	(B)	1	(C)	1	(E)	2
4	SX o DX	PUMA.1.5300.4050.N	(A)	1	(B)	1	(C)	2	(E)	2
5	SX o DX	PUMA.1.5300.4050.N	(A)	1	(B)	1	(C)	2	(E)	3
6	SX o DX	PUMA.1.5300.6070.N	(A)	1	(B)	1	(C)	3	(E)	3
7	SX o DX	PUMA.1.5300.6070.N	(A)	1	(B)	1	(C)	3	(E)	4
8	SX o DX	PUMA.1.5300.8090.N	(A)	1	(B)	1	(C)	4	(E)	4
9	SX o DX	PUMA.1.5300.8090.N	(A)	1	(B)	1	(C)	4	(E)	5
10	SX o DX	PUMA.1.5300.9091.N	(A)	1	(B)	1	(C)	5	(E)	5
11	SX o DX	PUMA.1.5300.9091.N	(A)	1	(B)	1	(C)	5	(E)	6
12	SX o DX	PUMA.1.5300.9293.N	(A)	1	(B)	1	(C)	6	(E)	6
13	SX o DX	PUMA.1.5300.9293.N	(A)	1	(B)	1	(C)	6	(E)	7

NA = Numero Porte (Ante).

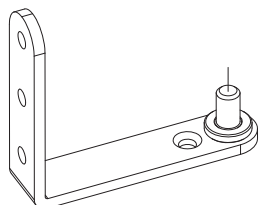
Con Fulcro Infer. "piatto" : **A2**



TABELLA KIT "PUMA.5310" SX o DX, con Fulcro Infer. "A2", con riferim. q.tà gruppi:

**OPTIONAL :**  
PUMA.5338.E

NA	RIF. KIT	Codice KIT- Fulcro a Pavimento	Rif.	Q.tà	Rif.	Q.tà	Rif.	Q.tà	Rif.	Q.tà
2	SX o DX	PUMA.1.5310.2030.N	(A2)	1	(B)	1	(C)	1	(E)	1
3	SX o DX	PUMA.1.5310.2030.N	(A2)	1	(B)	1	(C)	1	(E)	2
4	SX o DX	PUMA.1.5310.4050.N	(A2)	1	(B)	1	(C)	2	(E)	2
5	SX o DX	PUMA.1.5310.4050.N	(A2)	1	(B)	1	(C)	2	(E)	3
6	SX o DX	PUMA.1.5310.6070.N	(A2)	1	(B)	1	(C)	3	(E)	3
7	SX o DX	PUMA.1.5310.6070.N	(A2)	1	(B)	1	(C)	3	(E)	4
8	SX o DX	PUMA.1.5310.8090.N	(A2)	1	(B)	1	(C)	4	(E)	4
9	SX o DX	PUMA.1.5310.8090.N	(A2)	1	(B)	1	(C)	4	(E)	5
10	SX o DX	PUMA.1.5310.9091.N	(A2)	1	(B)	1	(C)	5	(E)	5
11	SX o DX	PUMA.1.5310.9091.N	(A2)	1	(B)	1	(C)	5	(E)	6
12	SX o DX	PUMA.1.5310.9293.N	(A2)	1	(B)	1	(C)	6	(E)	6
13	SX o DX	PUMA.1.5310.9293.N	(A2)	1	(B)	1	(C)	6	(E)	7

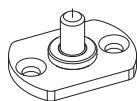

Schemi ingombri per Binario Incassato e per applicazioni con Carton Gesso.

**Binario Incassato:**

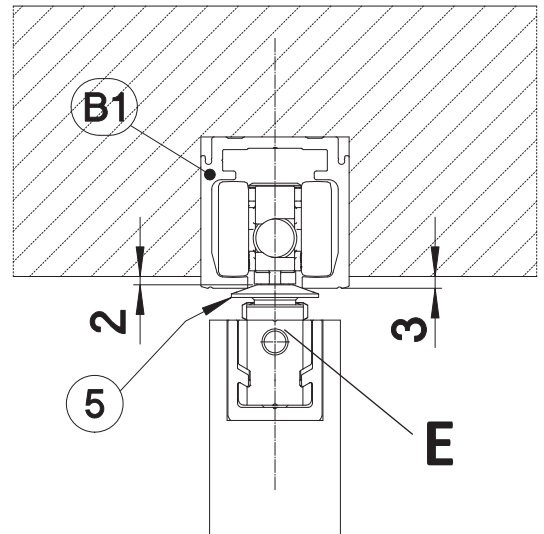
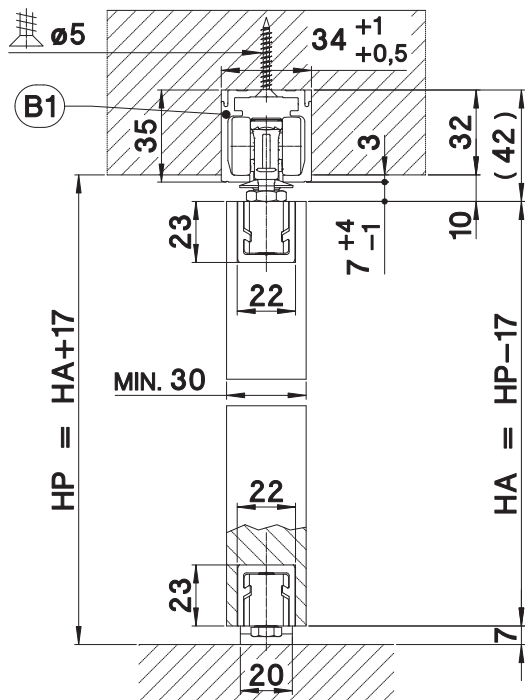

Sporgenza inferiore del Binario (B1) necessaria per il funzionamento del Fermo Molleggiato (5)

**Carton Gesso:**

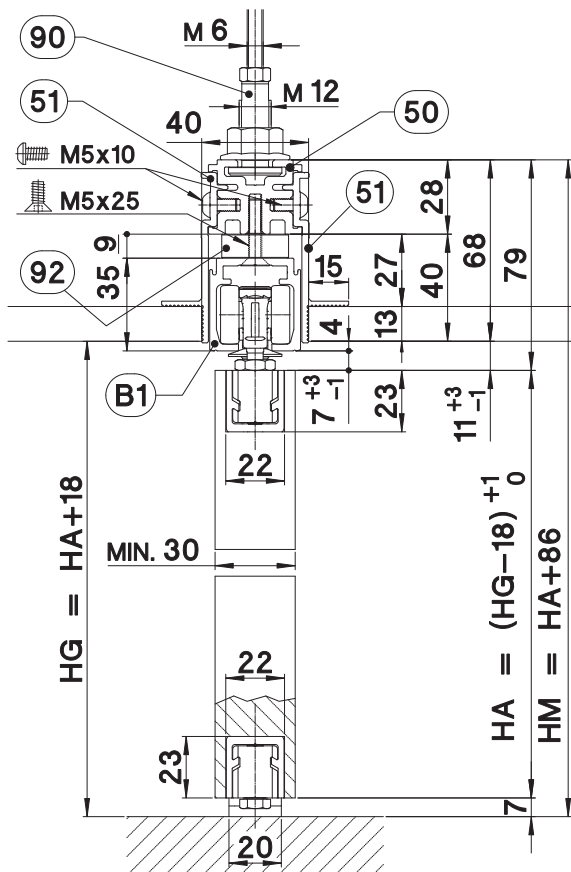

Sporgenza inferiore del Binario (B1) necessaria per il funzionamento del Fermo Molleggiato

(92) Distanziale per Binario da inserire nei profili per Carton Gesso

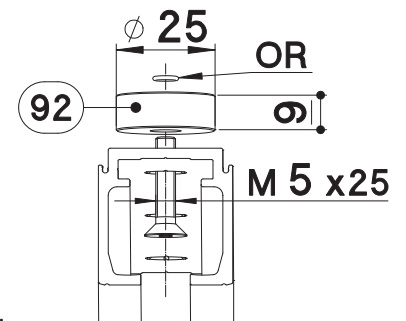

1.

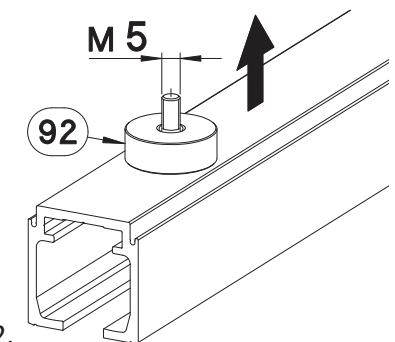

2.

Parte	Codice per NR.1 Kit : distaziale + vite + Or
(92)	PUMA.1930.K

Prevedere NR.1 Kit ogni 450 mm

Per i riferimenti dei profili (50) e (51), dell'accessorio (92) andare alle pagine "Composizioni Carton Gesso Legno" delle pagine del catalogo Sliding, riferimento "PUMA".



Inserimento gruppi + Bloccaggio Baionetta, Riferimento Gruppo "B" e Gruppo "A", fulcri fissi.

Premontaggio parte Fissa Baionetta.

Per una corretta posizione della parte, consigliato l'utilizzo di una punta a Centraggio prima dell'inserimento delle viti di fissaggio.

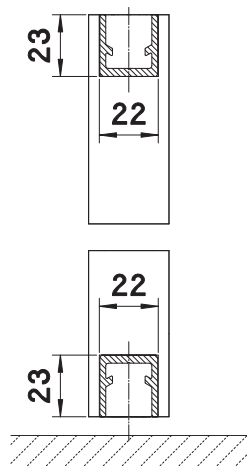
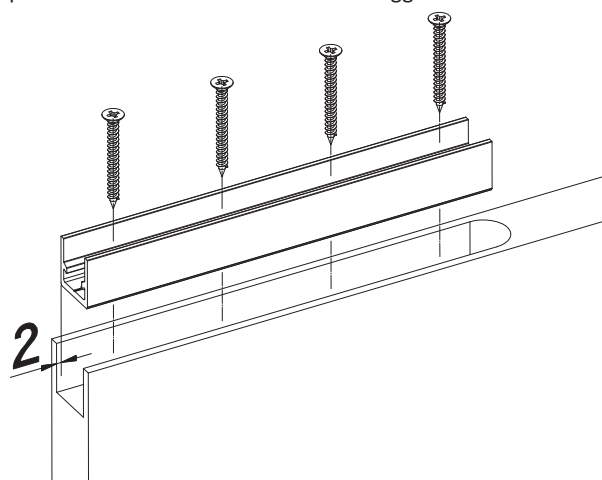

- Dima per posizione dei 2 mm interni

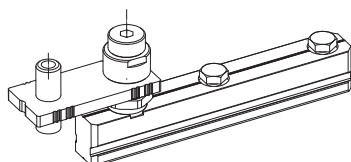
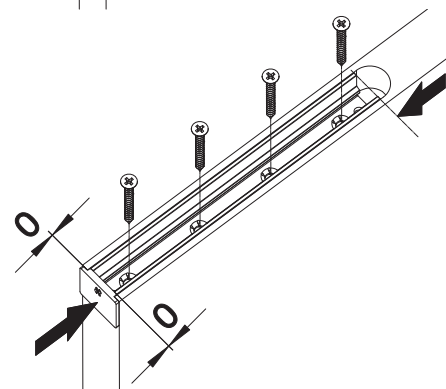
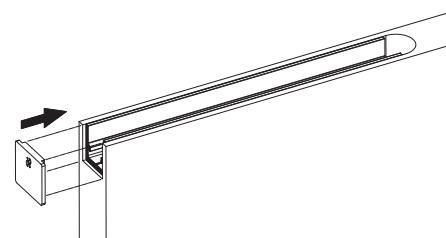
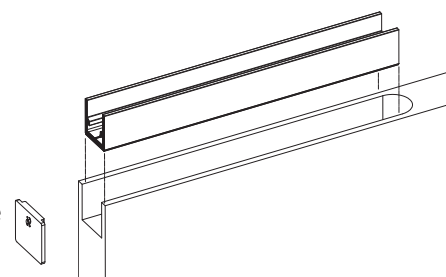

1.

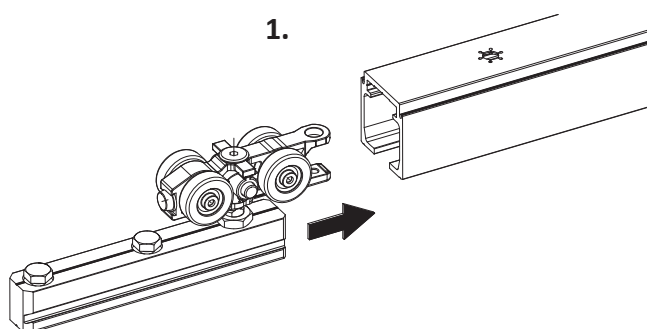

2.

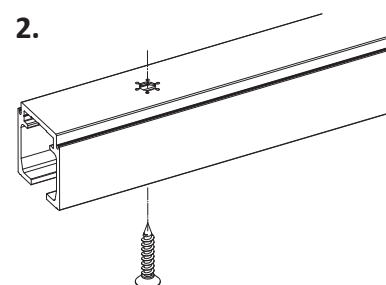



3.

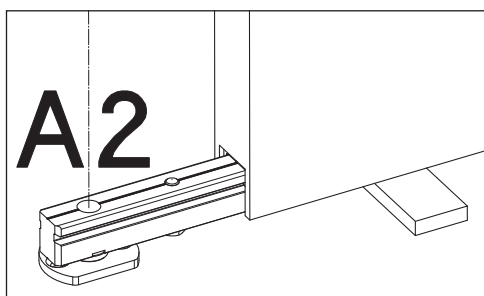
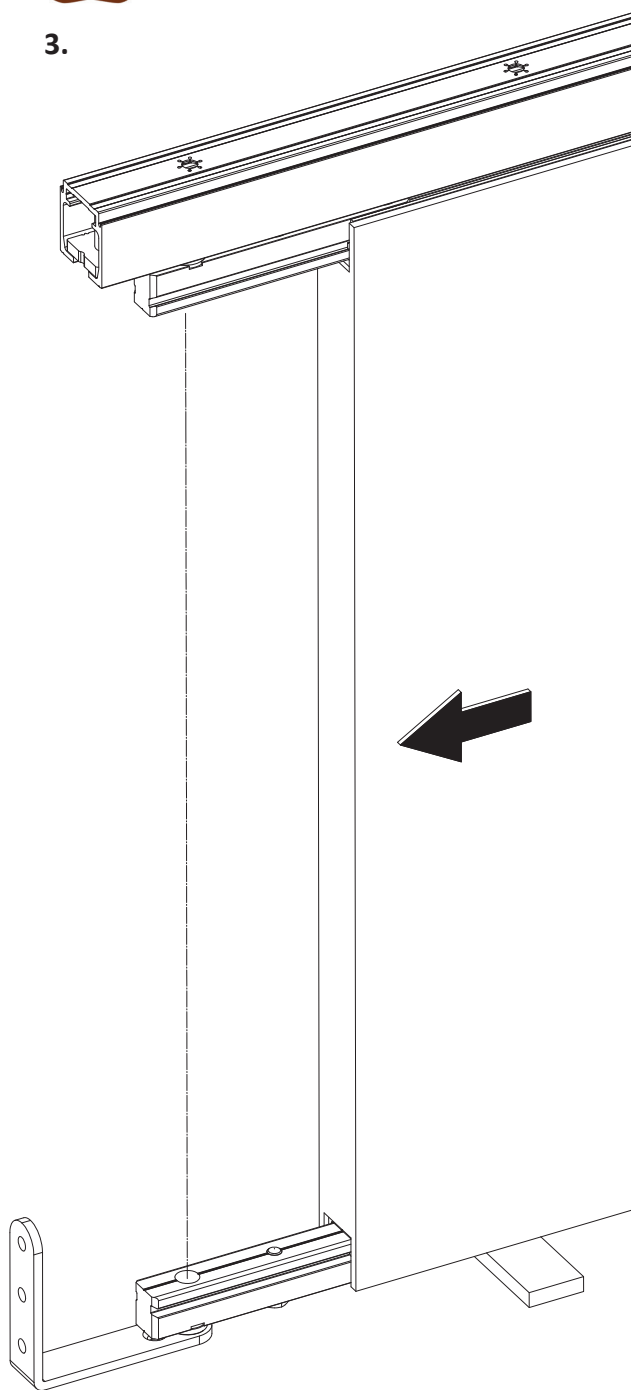

4.

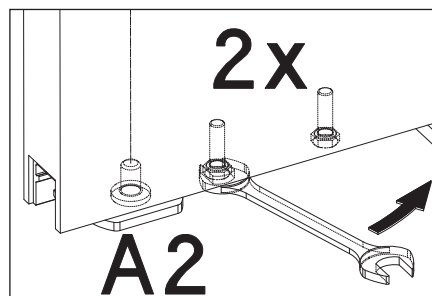
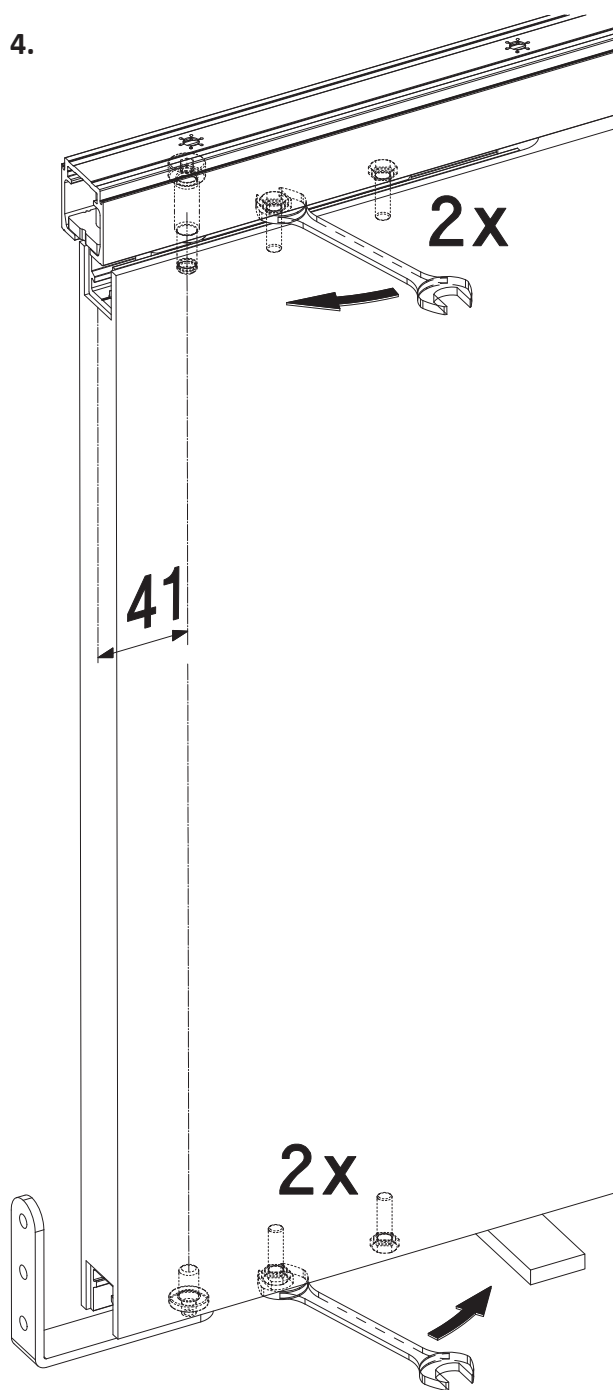

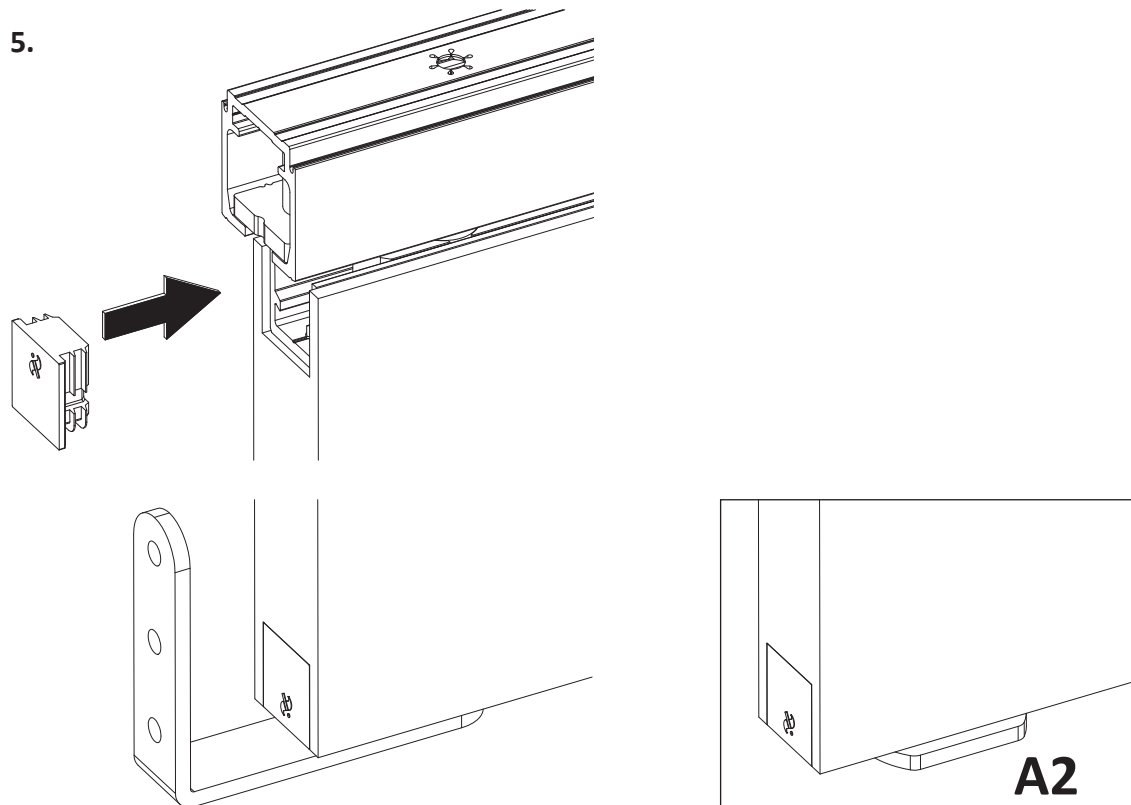

OPTIONAL Maschio Baionetta Fermo Molleggiato "5"

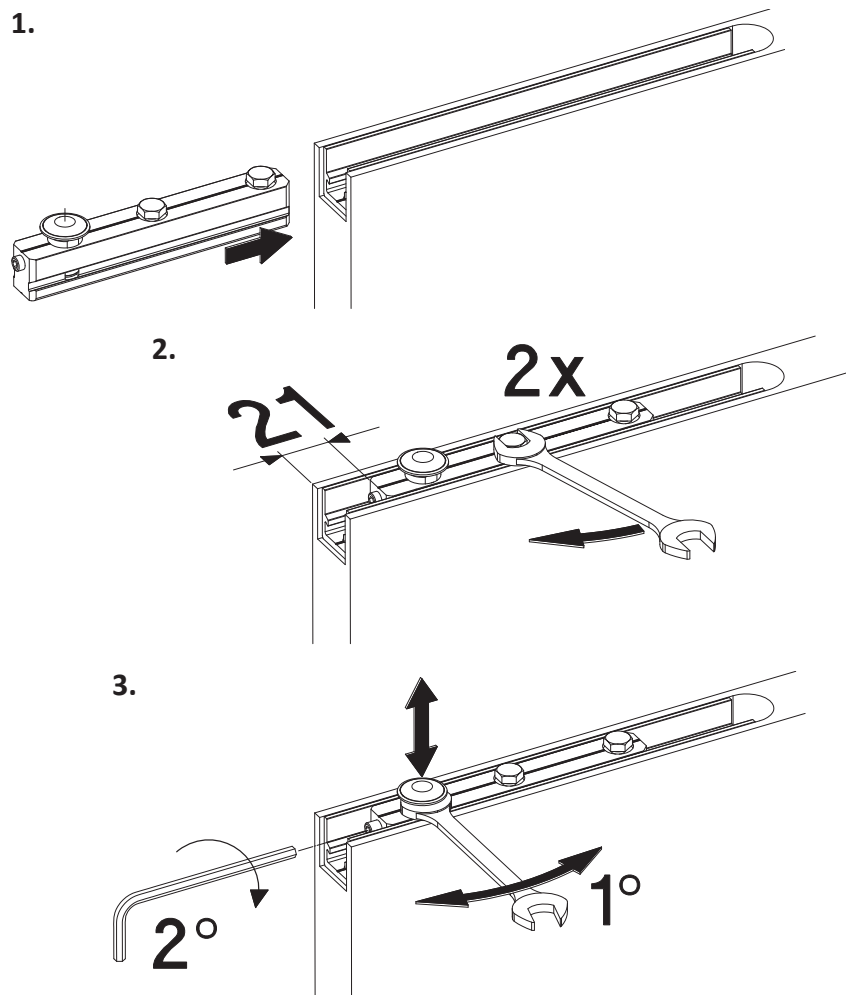



Inserimento, regolazione e bloccaggio Baionetta, Riferimento Gruppo "C", porta Carrello (9).

**1. Inserimento Maschio Baionetta**

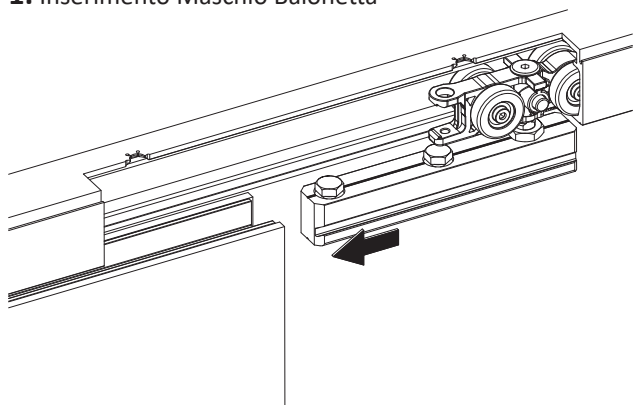

**2. Regolazione Verticale Porta**

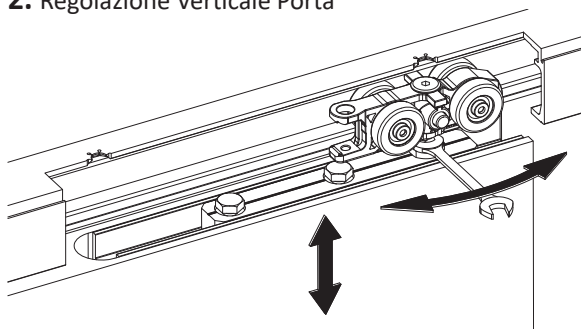

**3. Bloccaggio posizione Verticale Porta**

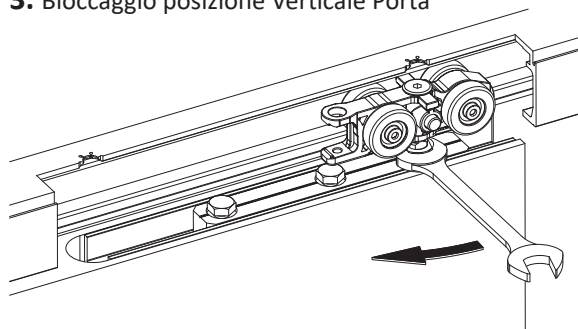

**4. Bloccaggio Maschio Baionetta in posizione (int.41 mm)**

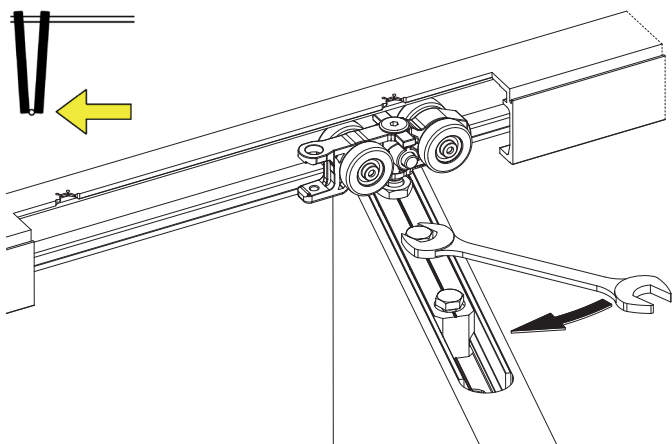

**5. Inserimento a pressione Tappo**

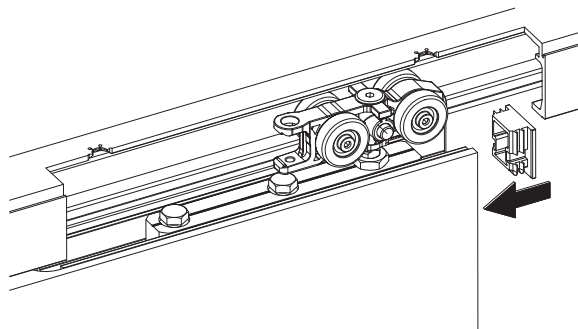



Porte Libro - A Baionetta # Versione Speciale : Con Guida a Pavimento.

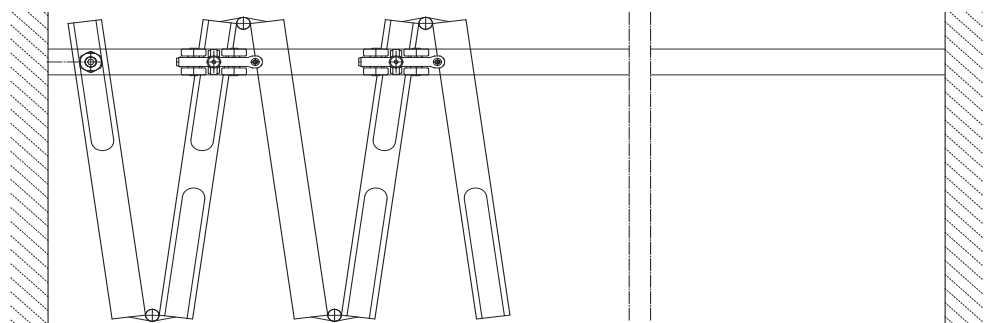

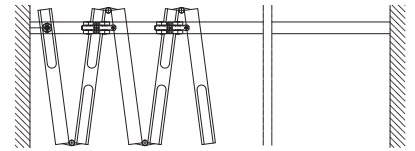

**PUMA.5302 per 2, 3, 4, 5 PORTE LEGNO LIBRO - Sistema con Guida Inferiore - MONTAGGIO Frontale a BAIONETTA**

Sistema pratico di montaggio e regolazione a Baionetta, ricavato da estrusi in alluminio.

Nei KIT sono compresi i Carrelli di scorrimento, per una eventuale alternativa di questi, andare a pag.18 e 19.

- Spessore Porte : da 30 a 55 mm compresi.
- Larghezza minima Porta : 400\* mm (con "C" + "E") | \*( Senza "E", Larghezza minima Porta = 210 mm ).
- Larghezza massima Porta consigliata : 900 mm

# Versione Speciale : CON Kit [(D)+(10)] di GUIDA Porte a PAVIMENTO.

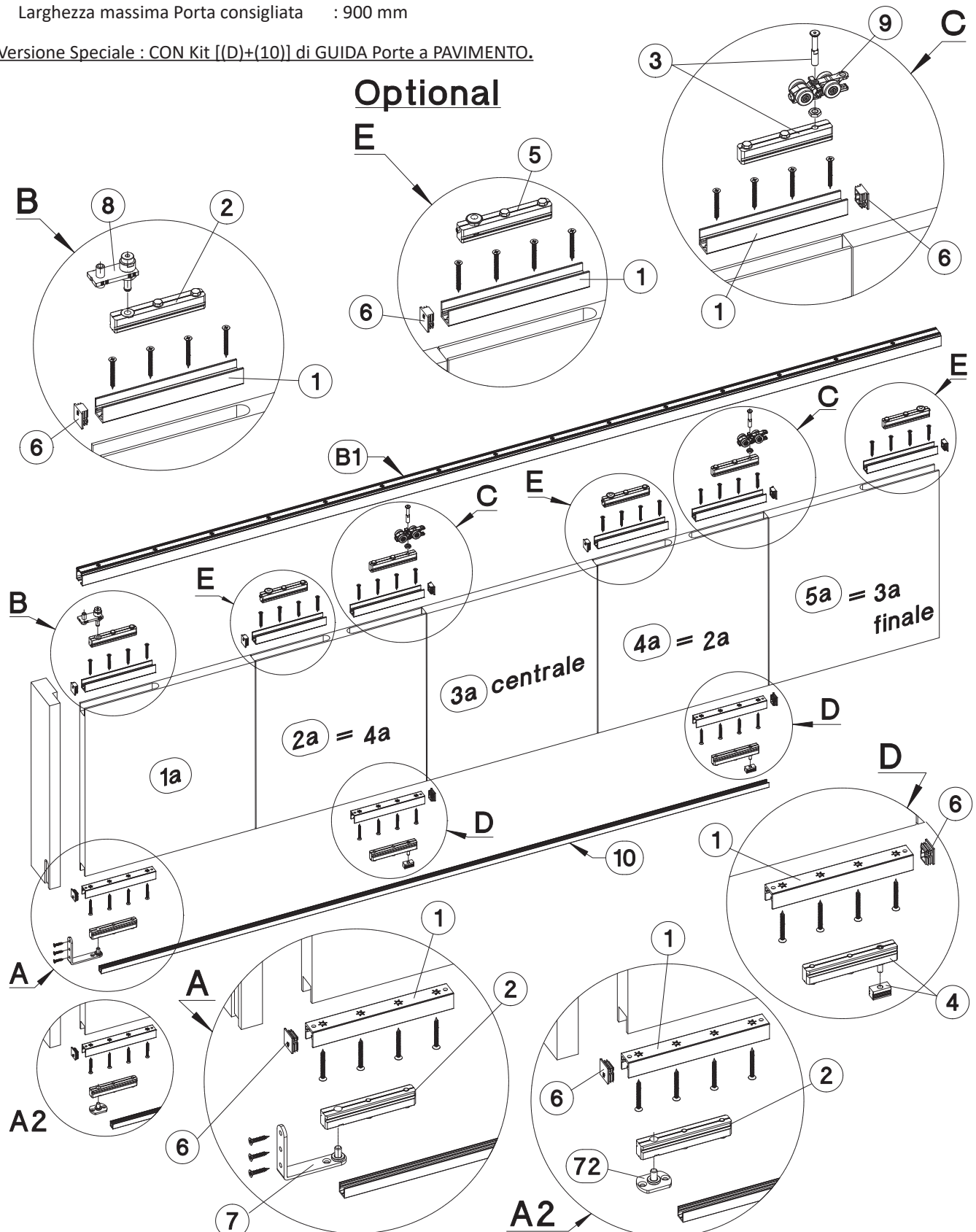

Porte Libro - A Baionetta # Versione Speciale : Con Guida a Pavimento.

Dettaglio COMPONENTI:

Riferim.	Immagine	Codice Identificativo riferito a NR.1 Pz o Kit (salvo diversa indicazione)																														
(1)		Parte Fissa Baionetta L = 186 mm. Alluminio estruso, finitura Naturale. Completo di fori svasati per il fissaggio. # Codice: <b>PUMA . 5302</b>																														
(2)		Parte Maschio Baionetta <u>con Bussola Foro ø 8 mm.</u> Alluminio estruso, finitura Naturale. Completo di due Viti TE M6 per il bloccaggio in posizione. # Codice: <b>PUMA . 5334 . K</b>																														
(3)		Parte Maschio Baionetta <u>con Filetto Femmina M8.</u> Alluminio estruso, finitura Naturale. Completo di: NR.2 Viti TE M6 per il bloccaggio in posizione e NR.1 Vite M8 per il collegamento al Carrello (9). # Codice: <b>PUMA . 5332 . K</b>																														
(4)		Parte Maschio Baionetta <u>con Filetto Femmina M8.</u> Alluminio estruso, finitura Naturale. Completo di: NR.2 Viti TE M6 per il bloccaggio in posizione e <b>NR.1 Pattino GUIDA Inferiore al Binario (10).</b> # Codice: <b>PUMA . 5333 . K</b>																														
(5)		<b>OPTIONAL:</b> Parte Maschio Baionetta <u>con Fermo molleggiato M14.</u> Alluminio estruso, finitura Naturale. Completo di: NR.2 Viti TE M6 per il bloccaggio in posizione e NR.1 perno molleggiato M14 uso Fermo sotto il binario (B1) . # Codice: <b>PUMA . 5338 . K</b>																														
(6)		Tappo di chiusura di testa fresata frontale Porta per (1). Plastica morbida, diversi colori # Codice: <b>PUMA . 5932</b>																														
(7)		VERSIONE (A): Fulcro Fisso Inferiore a "L" - DX/SX <u>con Perno ø 8 mm.</u> Per fissaggio retro telaio. Acciaio. # Codice: <b>PUMA . 8030</b>																														
(72)		VERSIONE (A2): Fulcro Fisso Inferiore "Piatto", <u>con Perno ø 8 mm.</u> Per <b>fissaggio al Pavimento.</b> Acciaio. # Codice: <b>PUMA . 8032</b>																														
(8)		Fulcro Superiore DX/SX <u>con Perno ø 8 mm.</u> Posizione Regolabile. Acciaio. # Codice: <b>PUMA . 8180</b>																														
(9)		Carrello <b>Dragon Kg 140</b> (riferito a nr. 2 Carrelli) Corpo in Tecnopolimero DRAGON (esclusivo materiale SLIDING). <b>Con nr.4 Cuscinetti rettificati</b> a carrello, rivestiti in Delrin. # Codice: <b>PUMA . 6 . 2140</b>																														
(B1)		<table border="1"> <thead> <tr> <th>Binario singolo Max.240 Kg</th> <th>L [mm]</th> <th>Anodizzato Argento</th> </tr> </thead> <tbody> <tr> <td>Foratura a passo (150 mm)</td> <td>2000</td> <td>PUMA . 0101 . 2000 . A</td> </tr> <tr> <td>Foratura a passo (150 mm)</td> <td>2500</td> <td>PUMA . 0101 . 2500 . A</td> </tr> <tr> <td>Foratura a passo (150 mm)</td> <td>3000</td> <td>PUMA . 0101 . 3000 . A</td> </tr> <tr> <td>Foratura a passo (150 mm)</td> <td>6000</td> <td>PUMA . 0101 . 6000 . A</td> </tr> <tr> <th>Binario singolo Max.120 Kg</th> <th>L [mm]</th> <th>Alluminio Naturale</th> </tr> <tr> <td>Foratura a passo (150 mm)</td> <td>2000</td> <td>PUMA . 0151 . 2000 . Z</td> </tr> <tr> <td>Foratura a passo (150 mm)</td> <td>2500</td> <td>PUMA . 0151 . 2500 . Z</td> </tr> <tr> <td>Foratura a passo (150 mm)</td> <td>3000</td> <td>PUMA . 0151 . 3000 . Z</td> </tr> <tr> <td>Foratura a passo (150 mm)</td> <td>6000</td> <td>PUMA . 0151 . 6000 . Z</td> </tr> </tbody> </table>	Binario singolo Max.240 Kg	L [mm]	Anodizzato Argento	Foratura a passo (150 mm)	2000	PUMA . 0101 . 2000 . A	Foratura a passo (150 mm)	2500	PUMA . 0101 . 2500 . A	Foratura a passo (150 mm)	3000	PUMA . 0101 . 3000 . A	Foratura a passo (150 mm)	6000	PUMA . 0101 . 6000 . A	Binario singolo Max.120 Kg	L [mm]	Alluminio Naturale	Foratura a passo (150 mm)	2000	PUMA . 0151 . 2000 . Z	Foratura a passo (150 mm)	2500	PUMA . 0151 . 2500 . Z	Foratura a passo (150 mm)	3000	PUMA . 0151 . 3000 . Z	Foratura a passo (150 mm)	6000	PUMA . 0151 . 6000 . Z
Binario singolo Max.240 Kg	L [mm]	Anodizzato Argento																														
Foratura a passo (150 mm)	2000	PUMA . 0101 . 2000 . A																														
Foratura a passo (150 mm)	2500	PUMA . 0101 . 2500 . A																														
Foratura a passo (150 mm)	3000	PUMA . 0101 . 3000 . A																														
Foratura a passo (150 mm)	6000	PUMA . 0101 . 6000 . A																														
Binario singolo Max.120 Kg	L [mm]	Alluminio Naturale																														
Foratura a passo (150 mm)	2000	PUMA . 0151 . 2000 . Z																														
Foratura a passo (150 mm)	2500	PUMA . 0151 . 2500 . Z																														
Foratura a passo (150 mm)	3000	PUMA . 0151 . 3000 . Z																														
Foratura a passo (150 mm)	6000	PUMA . 0151 . 6000 . Z																														
(10)		<p>Profilo di Guida a Pavimento, in Alluminio ("Nibbio"), con fori svasati:</p> <ul style="list-style-type: none"> <li>Di serie, Anodizzato Argento: <b>1007701A</b> Lunghezza 3000 mm</li> </ul>																														

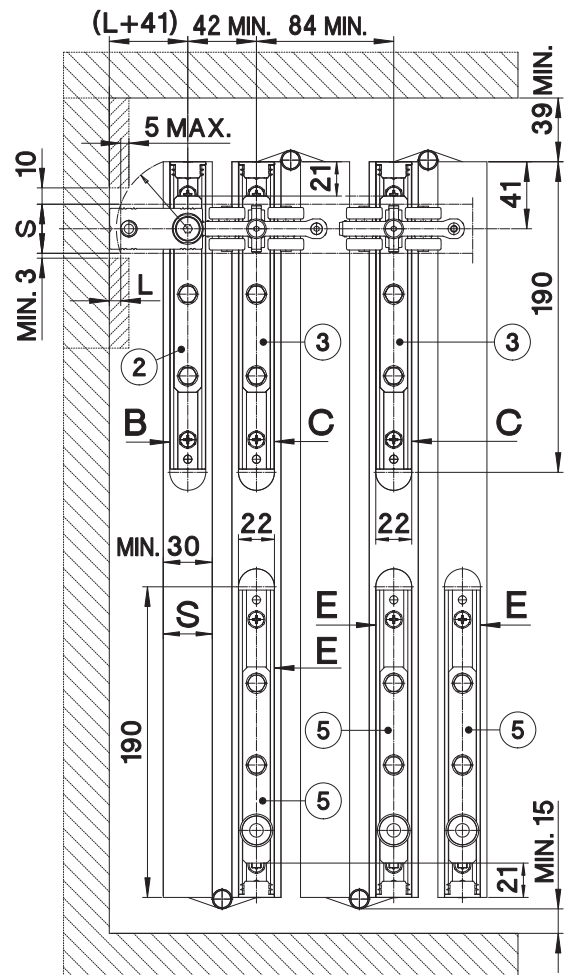
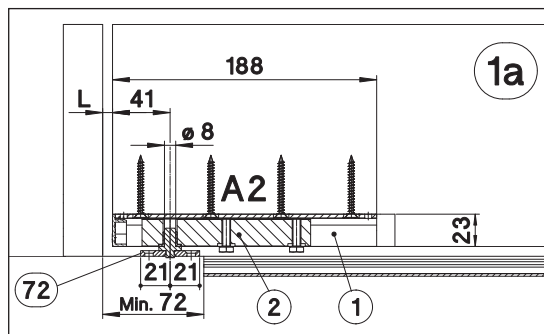
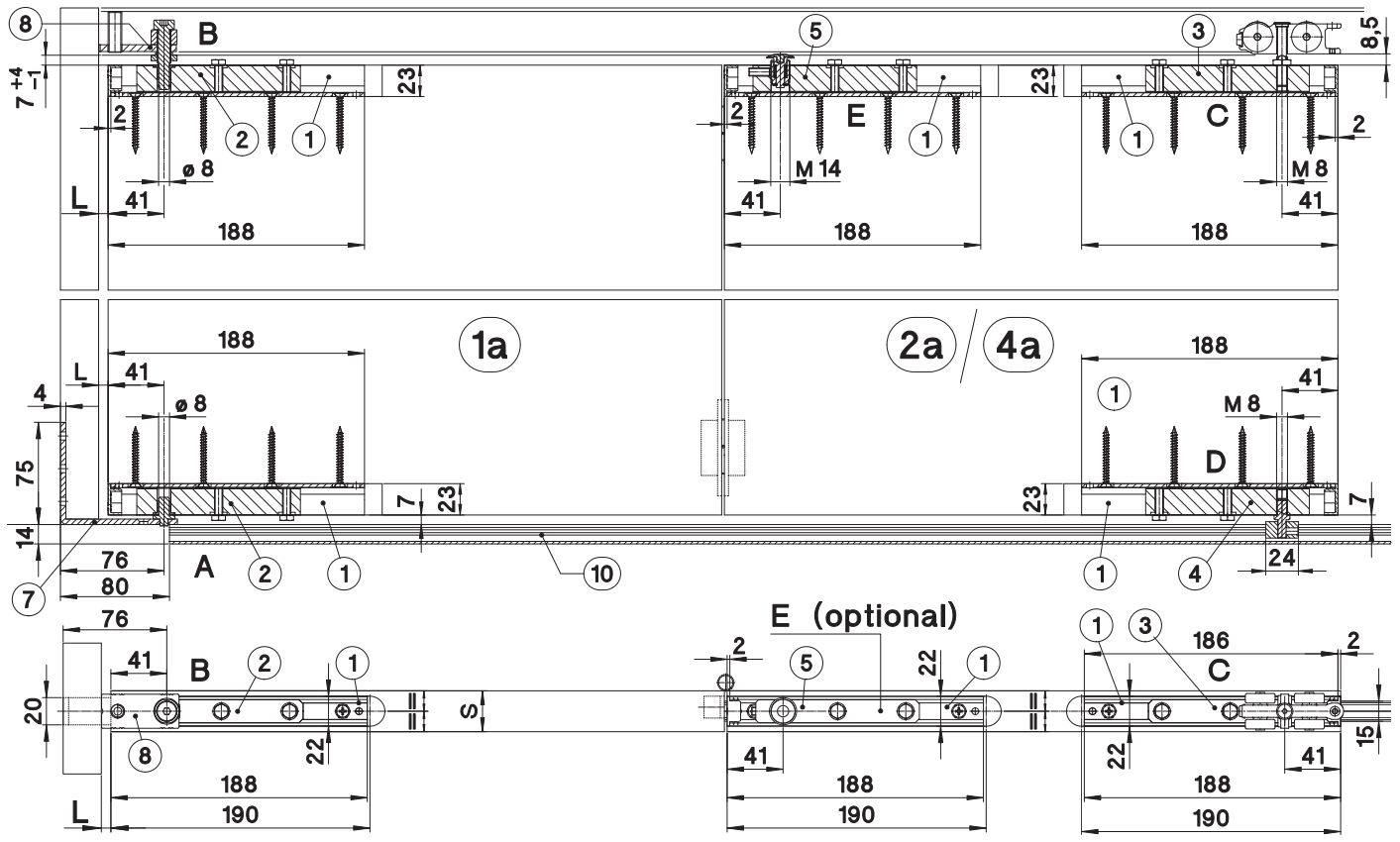

LEGENDA FORMULE / SCHEMI :

LA	= Larghezza Porta (Anta).
LV	= Larghezza Vano.
HA	= Altezza Porta (Anta).
HV	= Altezza Vano.
HP	= Altezza Passaggio.
NA	= Numero Porte (Ante).
1a...	= Porta (Anta) n° 1,2,3,4,5
L	= Luce Fuga.
S	= Spessore Porta (Anta).

Spessore Porta (S)	Luce Fuga (L)
Da 30 a 46 mm	7 mm
Da 47 a 50 mm	8 mm
Da 51 a 55 mm	9 mm



Porte Libro - A Baionetta # Versione Speciale : Con Guida a Pavimento.

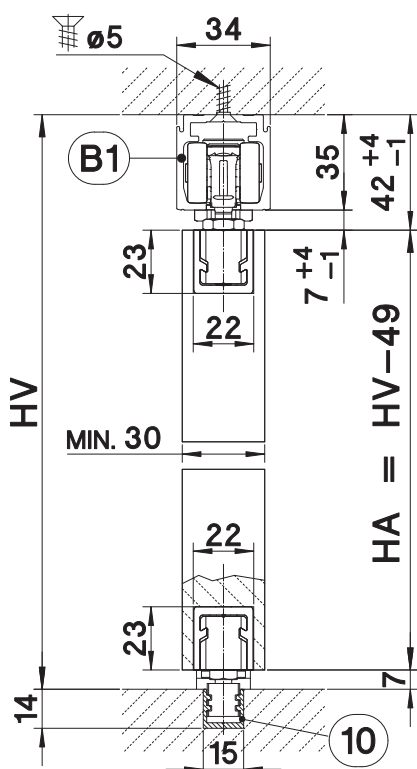
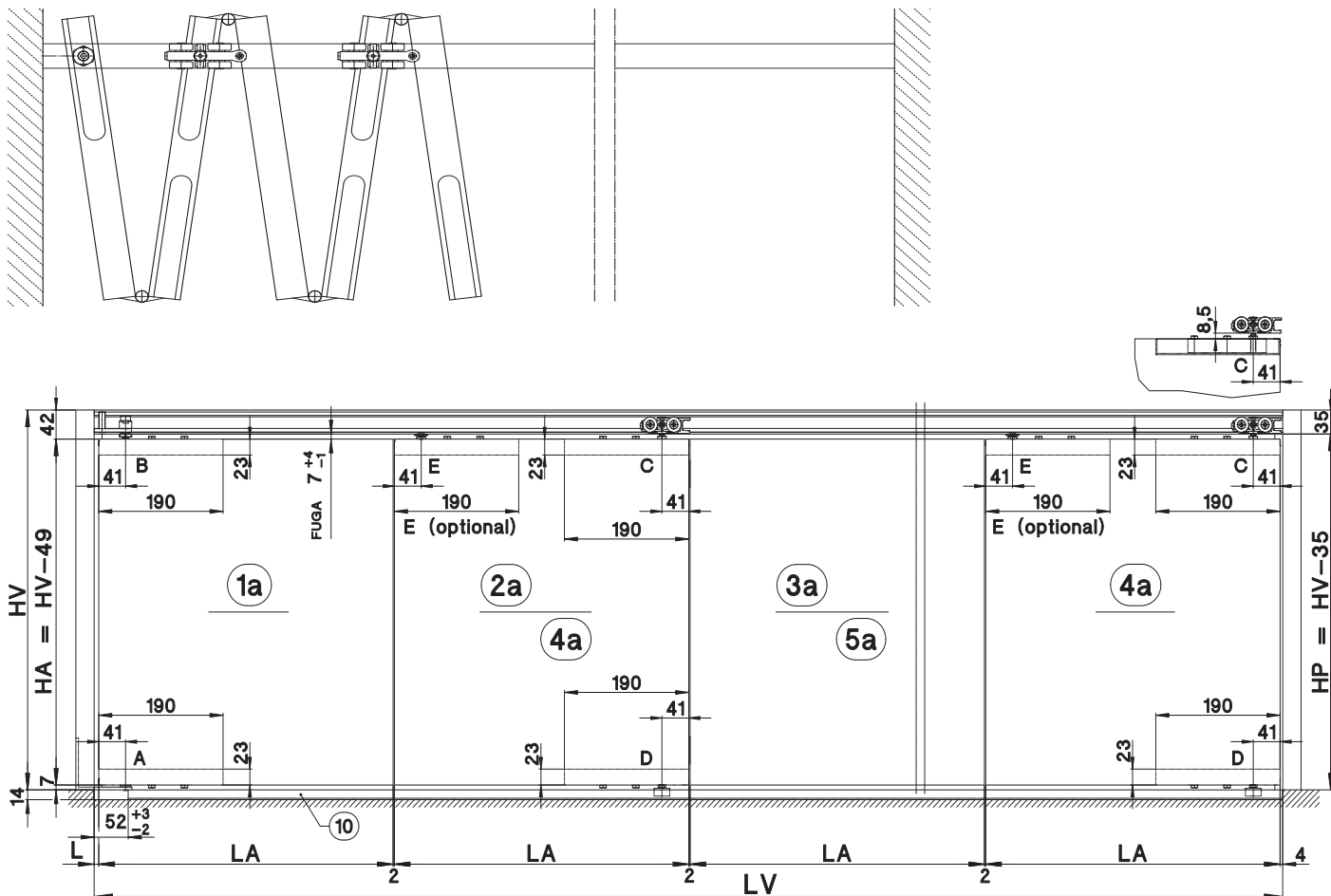

LEGENDA FORMULE / SCHEMI :

LA	= Larghezza Porta (Anta).
LV	= Larghezza Vano.
HA	= Altezza Porta (Anta).
HV	= Altezza Vano.
HP	= Altezza Passaggio.
NA	= Numero Porte (Ante).
1a...	= Porta (Anta) n° 1,2,3,4,5
L	= Luce Fuga.
S	= Spessore Porta (Anta).

Spessore Porta (S)	Luce Fuga (L)
Da 30 a 46 mm	7 mm
Da 47 a 50 mm	8 mm
Da 51 a 55 mm	9 mm

Con Binario esterno a vista.  
Per Binario Incassato e per Carton Gesso, vedere schemi nelle pagine seguenti, dopo le Tabelle dei KIT.

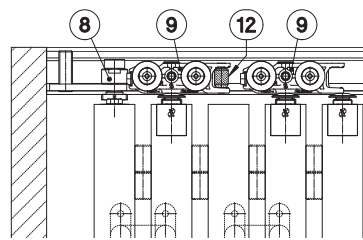

(12) Fermo da aggiungere in testa al primo Carrello (9) in caso di 4 o 5 Porte.  
# PUMA. 2590

Imputare i dati nella tabella per poi calcolare LA e HA.

LV =	
L =	
NA =	
HV =	

LA =	$\frac{[ LV - (L+4) ] - [ 2 \times (NA-1) ]}{NA}$	
HA =	HV - 49	



Esempi di composizioni

SX

DX

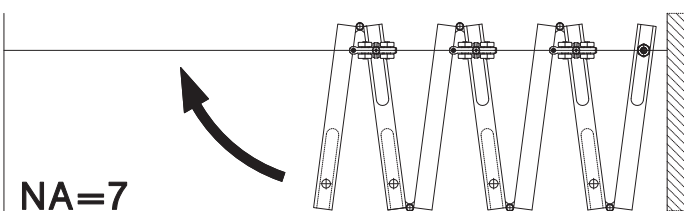
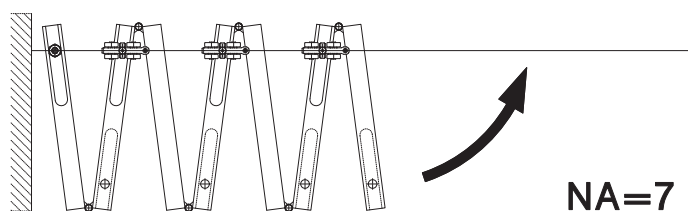
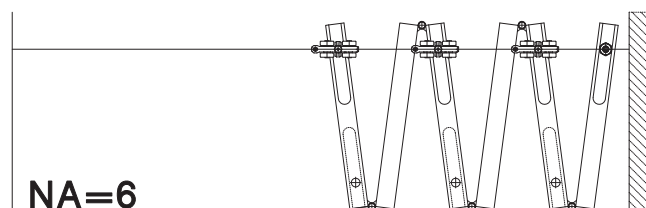
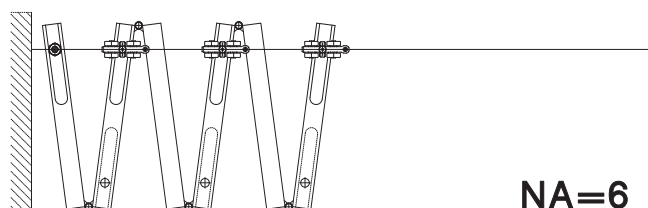
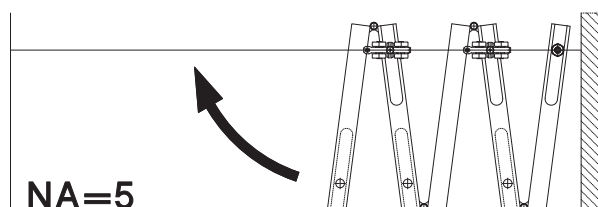
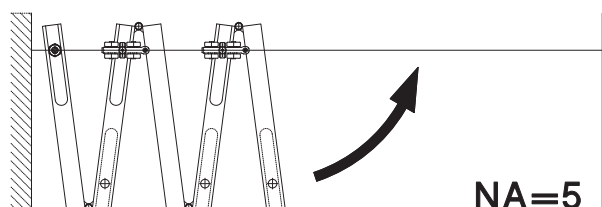
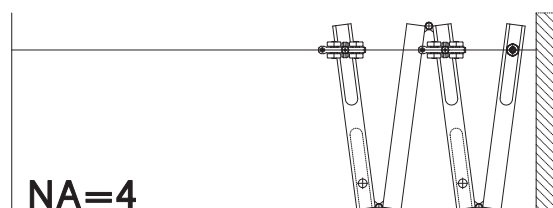
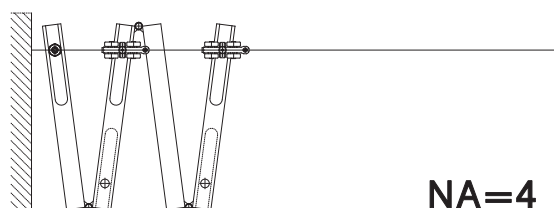
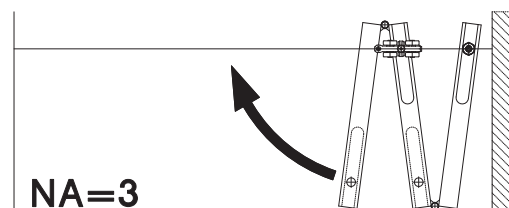
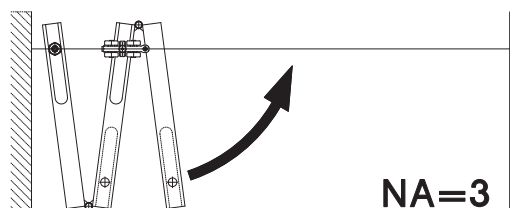
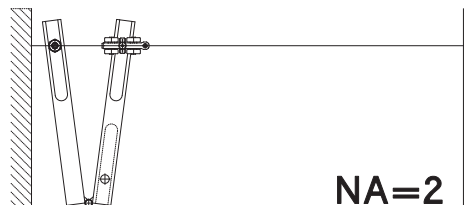

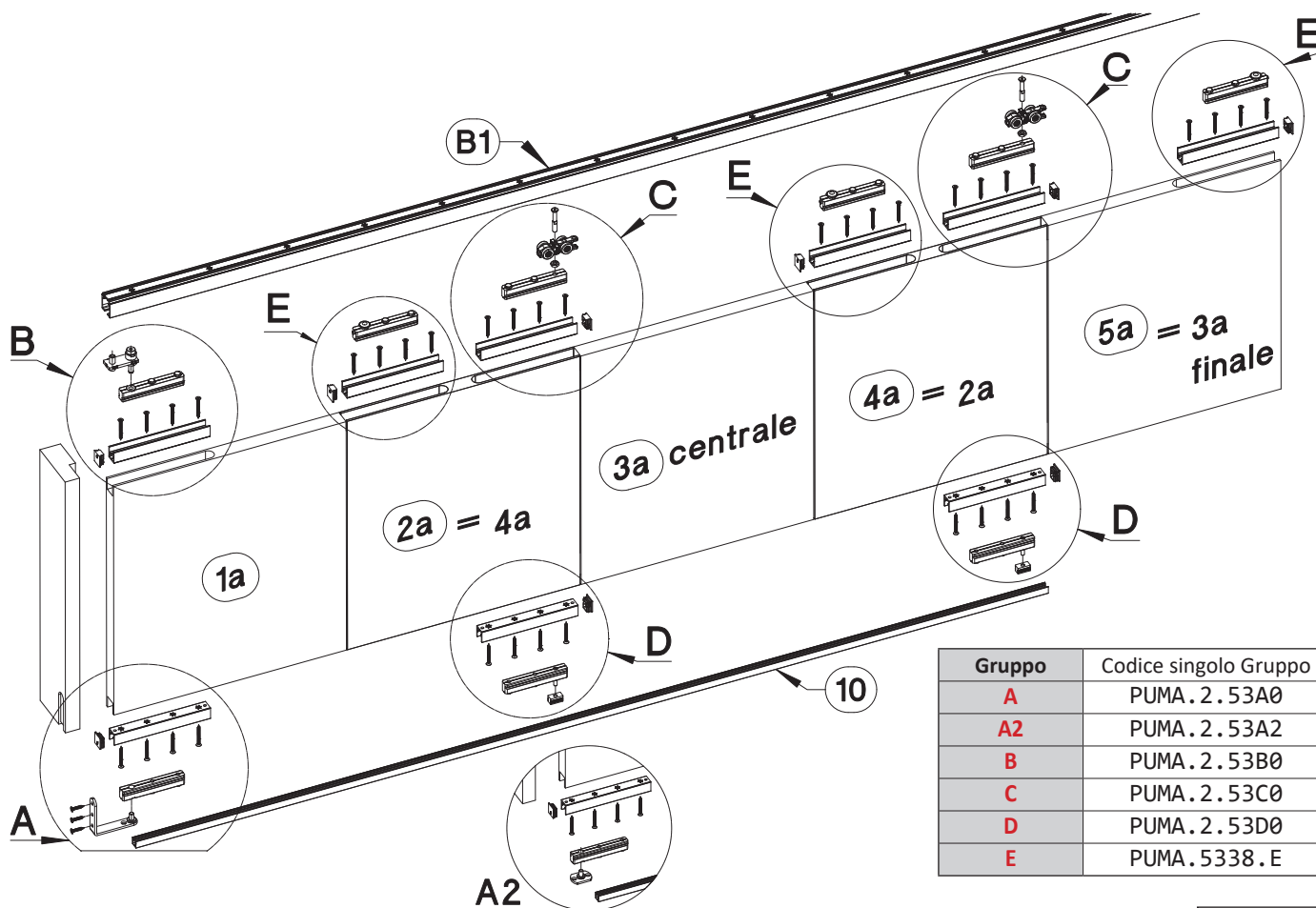

Gruppo	Codice singolo Gruppo
<b>A</b>	PUMA.2.53A0
<b>A2</b>	PUMA.2.53A2
<b>B</b>	PUMA.2.53B0
<b>C</b>	PUMA.2.53C0
<b>D</b>	PUMA.2.53D0
<b>E</b>	PUMA.5338.E

Con Fulcro Inferiore a "L"



TABELLA KIT "PUMA.5302" SX o DX, con Fulcro Inferiore "A", con riferim. q.tà gruppi:

NA	RIF. KIT	Codice KIT	Rif.	Q.tà	Rif.	Q.tà	Rif.	Q.tà	Rif.	Q.tà
2	SX o DX	PUMA.1.5302.2030.N	(A)	1	(B)	1	(C)	1	(D)	1
3	SX o DX	PUMA.1.5302.2030.N	(A)	1	(B)	1	(C)	1	(D)	1
4	SX o DX	PUMA.1.5302.4050.N	(A)	1	(B)	1	(C)	2	(D)	2
5	SX o DX	PUMA.1.5302.4050.N	(A)	1	(B)	1	(C)	2	(D)	2
6	SX o DX	PUMA.1.5302.6070.N	(A)	1	(B)	1	(C)	3	(D)	3
7	SX o DX	PUMA.1.5302.6070.N	(A)	1	(B)	1	(C)	3	(D)	3
8	SX o DX	PUMA.1.5302.8090.N	(A)	1	(B)	1	(C)	4	(D)	4
9	SX o DX	PUMA.1.5302.8090.N	(A)	1	(B)	1	(C)	4	(D)	4
10	SX o DX	PUMA.1.5302.9091.N	(A)	1	(B)	1	(C)	5	(D)	5
11	SX o DX	PUMA.1.5302.9091.N	(A)	1	(B)	1	(C)	5	(D)	5
12	SX o DX	PUMA.1.5302.9293.N	(A)	1	(B)	1	(C)	6	(D)	6
13	SX o DX	PUMA.1.5302.9293.N	(A)	1	(B)	1	(C)	6	(D)	6

**OPTIONAL:**  
PUMA.5338.E

Rif.	Q.tà
(E)	1
(E)	2
(E)	2
(E)	3
(E)	3
(E)	4
(E)	4
(E)	5
(E)	5
(E)	6
(E)	6
(E)	7

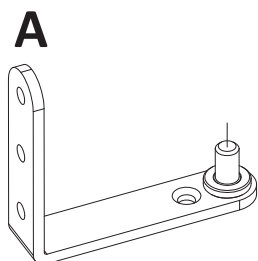
NA = Numero Porte (Ante).

Con Fulcro Infer. "piatto"



TABELLA KIT "PUMA.5312" SX o DX, con Fulcro Infer. "A2", con riferim. q.tà gruppi:

NA	RIF. KIT	Codice KIT- Fulcro a Pavim.	Rif.	Q.tà	Rif.	Q.tà	Rif.	Q.tà	Rif.	Q.tà
2	SX o DX	PUMA.1.5312.2030.N	(A2)	1	(B)	1	(C)	1	(D)	1
3	SX o DX	PUMA.1.5312.2030.N	(A2)	1	(B)	1	(C)	1	(D)	1
4	SX o DX	PUMA.1.5312.4050.N	(A2)	1	(B)	1	(C)	2	(D)	2
5	SX o DX	PUMA.1.5312.4050.N	(A2)	1	(B)	1	(C)	2	(D)	2
6	SX o DX	PUMA.1.5312.6070.N	(A2)	1	(B)	1	(C)	3	(D)	3
7	SX o DX	PUMA.1.5312.6070.N	(A2)	1	(B)	1	(C)	3	(D)	3
8	SX o DX	PUMA.1.5312.8090.N	(A2)	1	(B)	1	(C)	4	(D)	4
9	SX o DX	PUMA.1.5312.8090.N	(A2)	1	(B)	1	(C)	4	(D)	4
10	SX o DX	PUMA.1.5312.9091.N	(A2)	1	(B)	1	(C)	5	(D)	5
11	SX o DX	PUMA.1.5312.9091.N	(A2)	1	(B)	1	(C)	5	(D)	5
12	SX o DX	PUMA.1.5312.9293.N	(A2)	1	(B)	1	(C)	6	(D)	6
13	SX o DX	PUMA.1.5312.9293.N	(A2)	1	(B)	1	(C)	6	(D)	6

**OPTIONAL:**  
PUMA.5338.E

Rif.	Q.tà
(E)	1
(E)	2
(E)	2
(E)	3
(E)	3
(E)	4
(E)	4
(E)	5
(E)	5
(E)	6
(E)	6
(E)	7

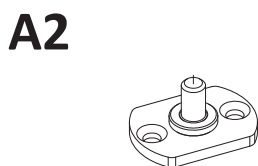

Schemi ingombri per Binario Incassato e per applicazioni con Carton Gesso.

**Binario Incassato:**

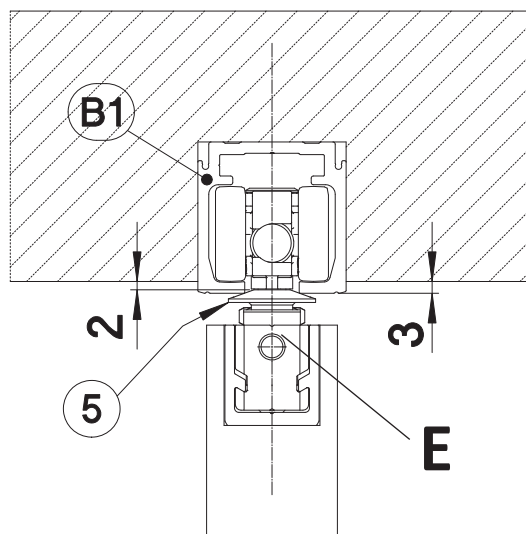
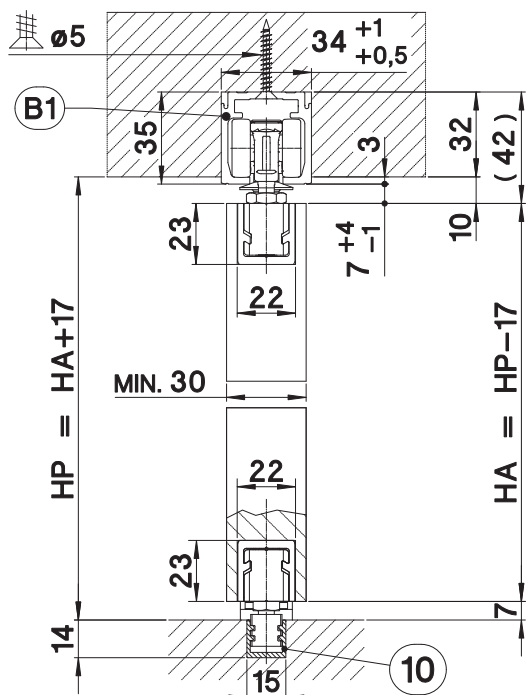

Sporgenza inferiore del Binario (B1) necessaria per il funzionamento del Fermo Molleggiato (5)

**Carton Gesso:**

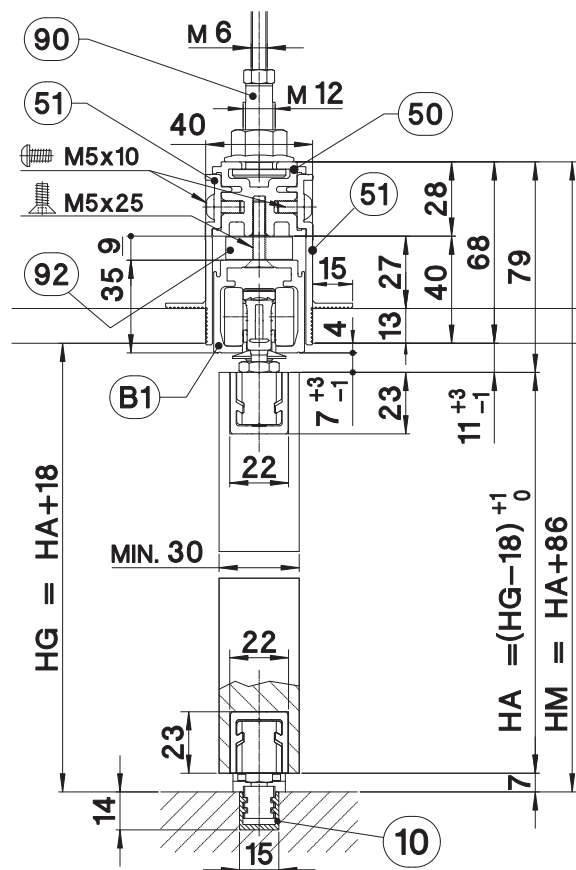

Sporgenza inferiore del Binario (B1) necessaria per il funzionamento del Fermo Molleggiato

(92) Distanziale per Binario da inserire nei profili per Carton Gesso

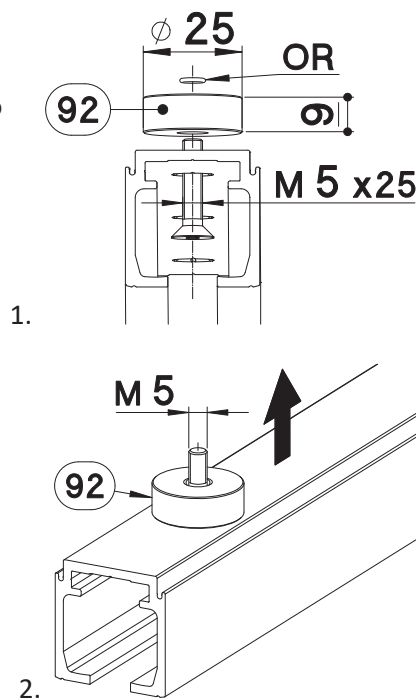

Parte	Codice per NR.1 Kit : distaziale + vite + Or
(92)	PUMA.1930.K

Prevedere NR.1 Kit ogni 450 mm

Per i riferimenti dei profili (50) e (51), dell'accessorio (92) andare alle pagine "Composizioni Carton Gesso Legno" delle pagine del catalogo Sliding, riferimento "PUMA".



Porte Libro - A Baionetta # Versione Speciale : Con Guida a Pavimento.

Inserimento gruppi + Bloccaggio Baionetta, Riferimento Gruppo "B" e Gruppo "A", fulcri fissi.

Premontaggio parte Fissa Baionetta.

Per una corretta posizione della parte, consigliato l'utilizzo di una punta a Centraggio prima dell'inserimento delle viti di fissaggio.

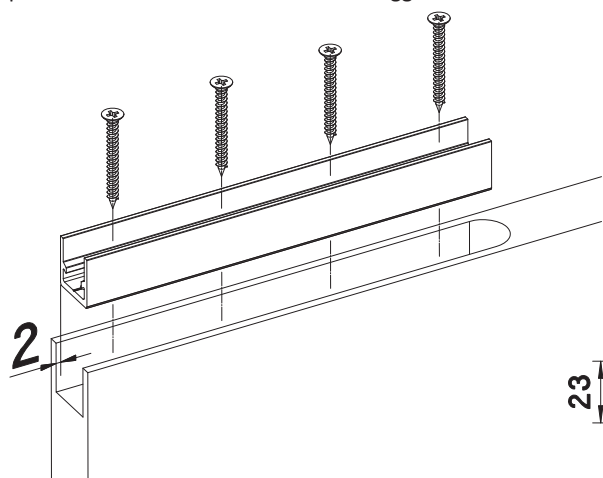

- Dima per posizione dei 2 mm interni

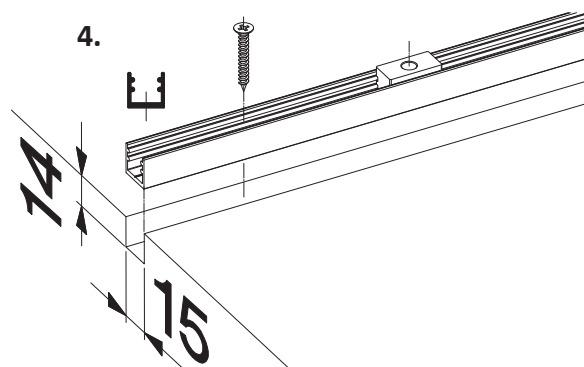
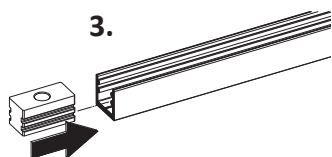
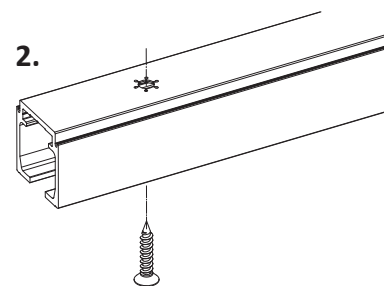
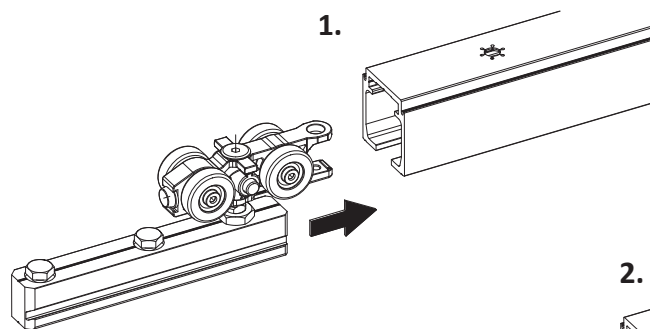
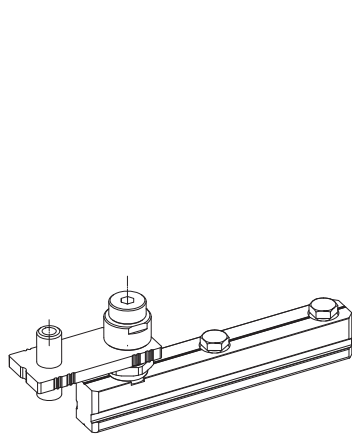
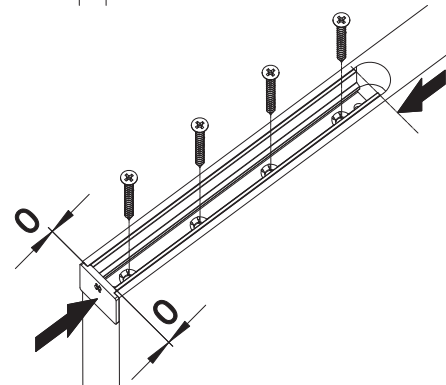
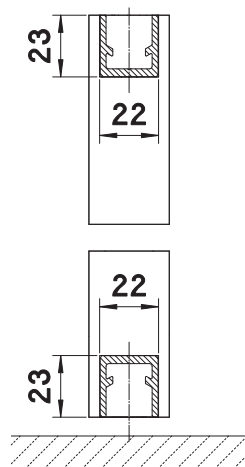
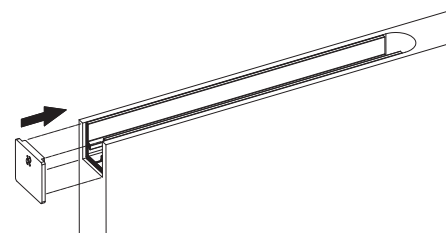
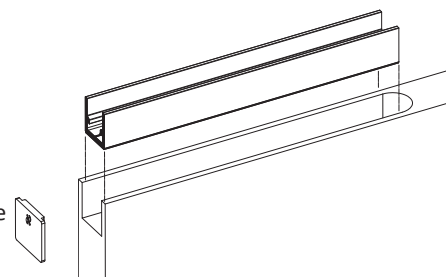



5.

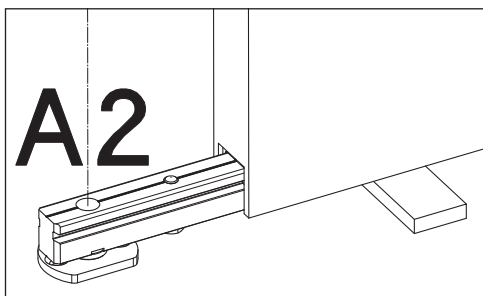
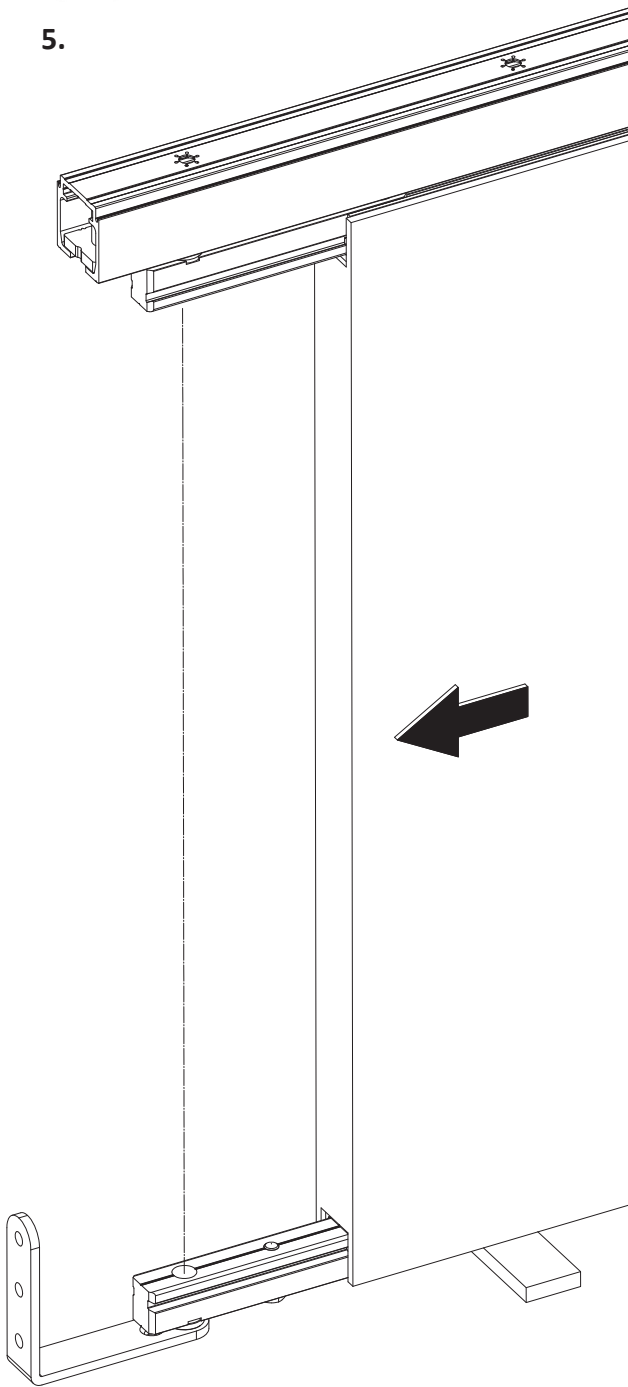

6.

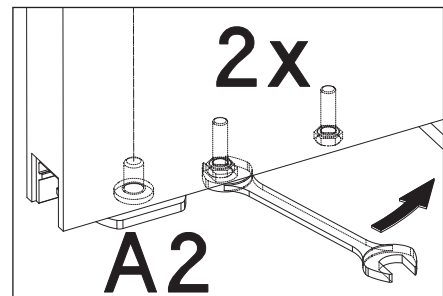
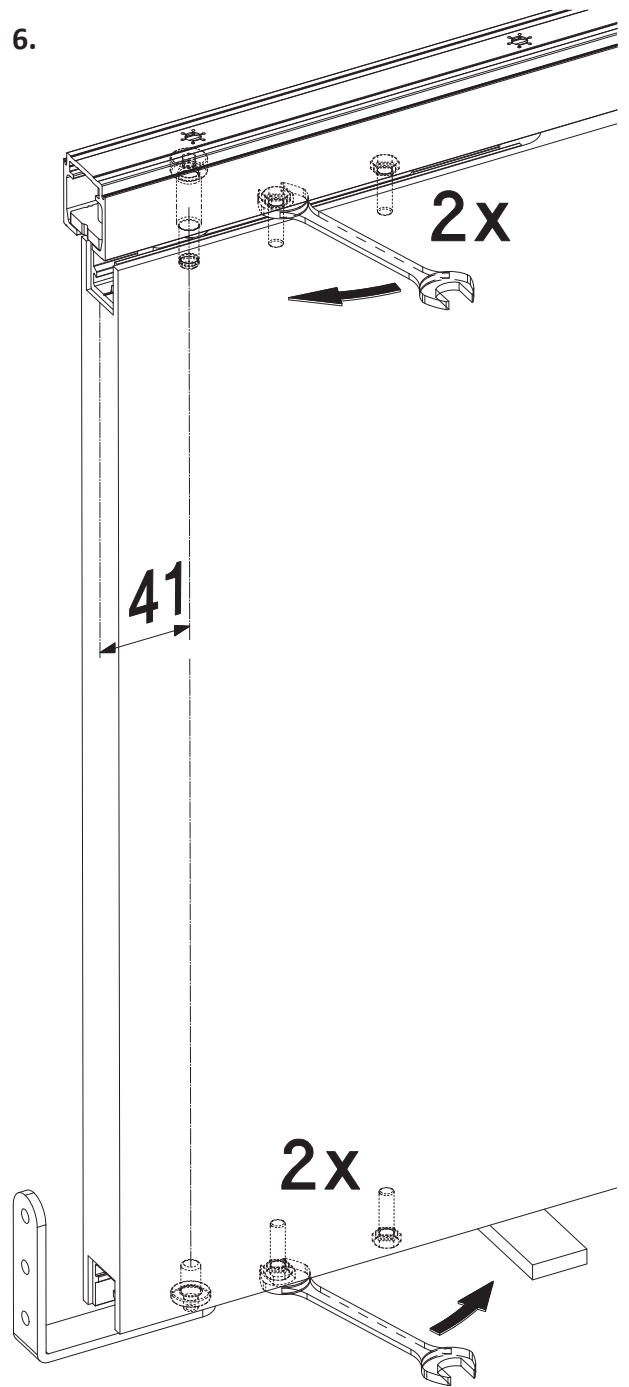



Porte Libro - A Baionetta # Versione Speciale : Con Guida a Pavimento.

7.

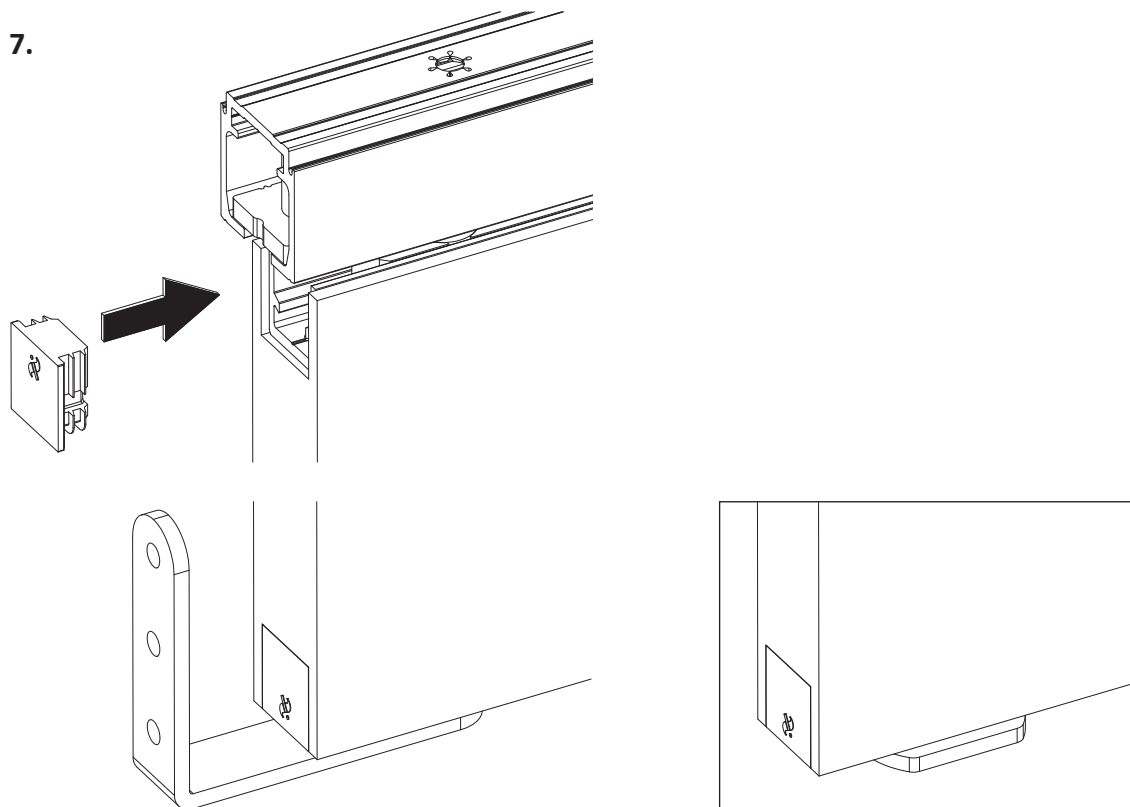

OPTIONAL Maschio Baionetta Fermo Molleggiato "5"

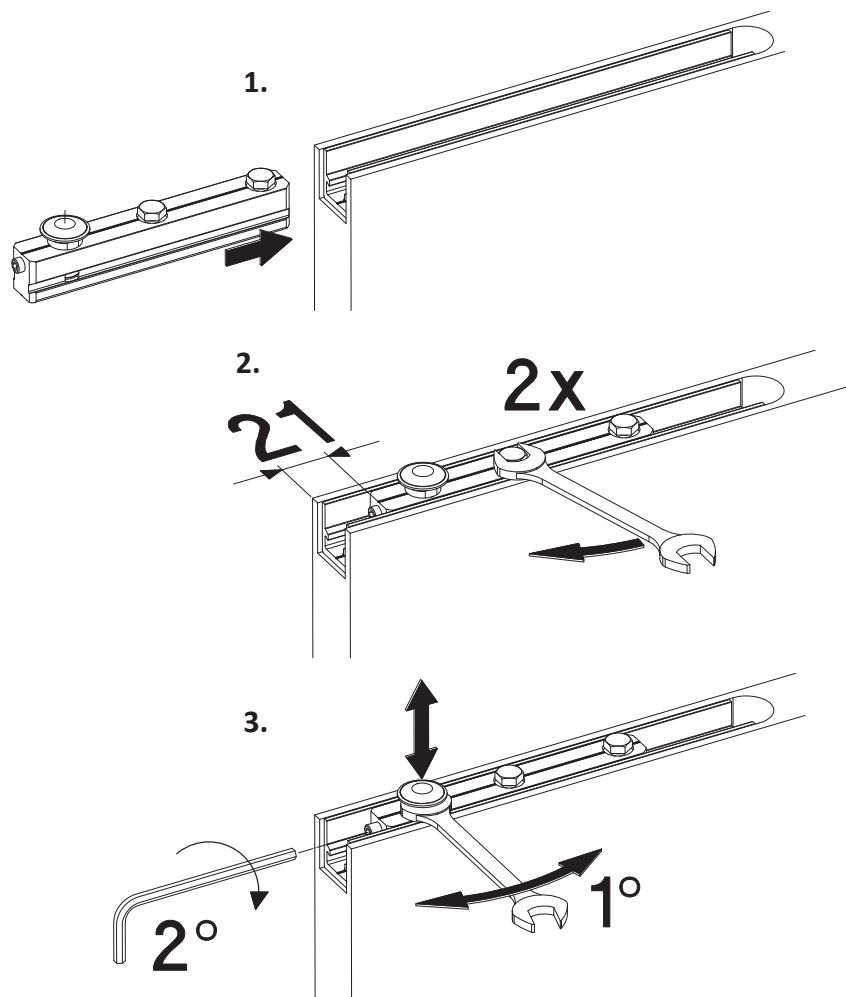



**2. Inserimento Maschi Baionetta**

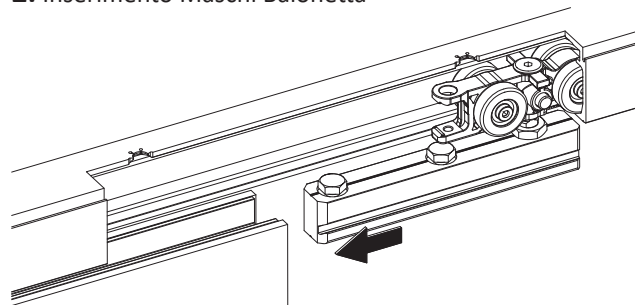

**1.**

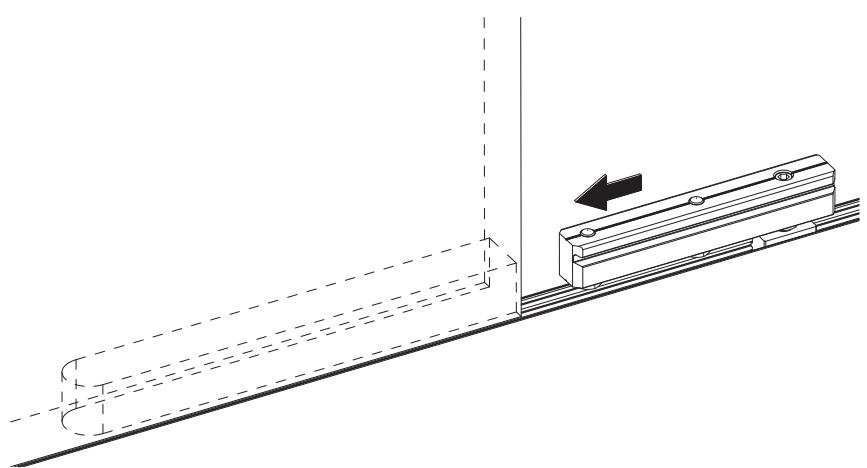
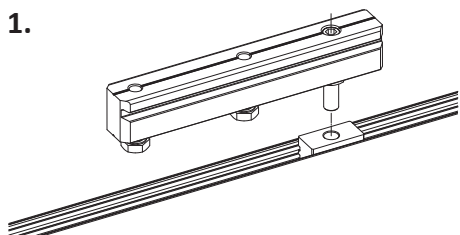

**3. Regolazione Verticale Porta dal Carrello**

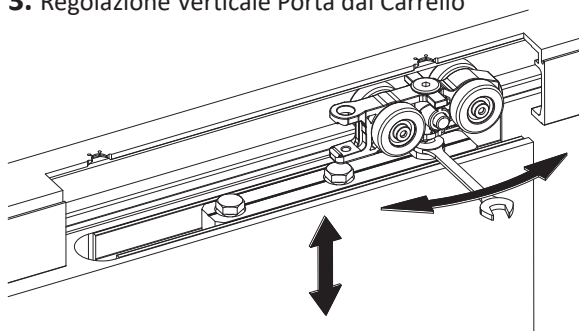

**4. Bloccaggio posizione Verticale Porta**

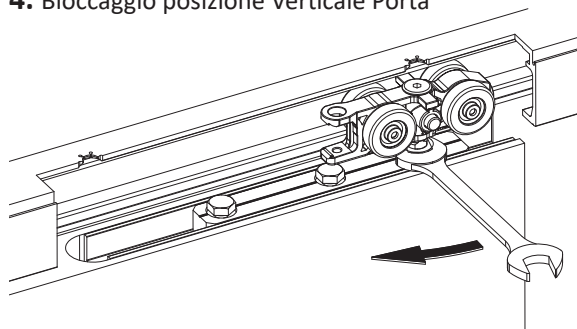



Porte Libro - A Baionetta # Versione Speciale : Con Guida a Pavimento.

4. Bloccaggio Maschio Baionetta in posizione (int.41 mm)

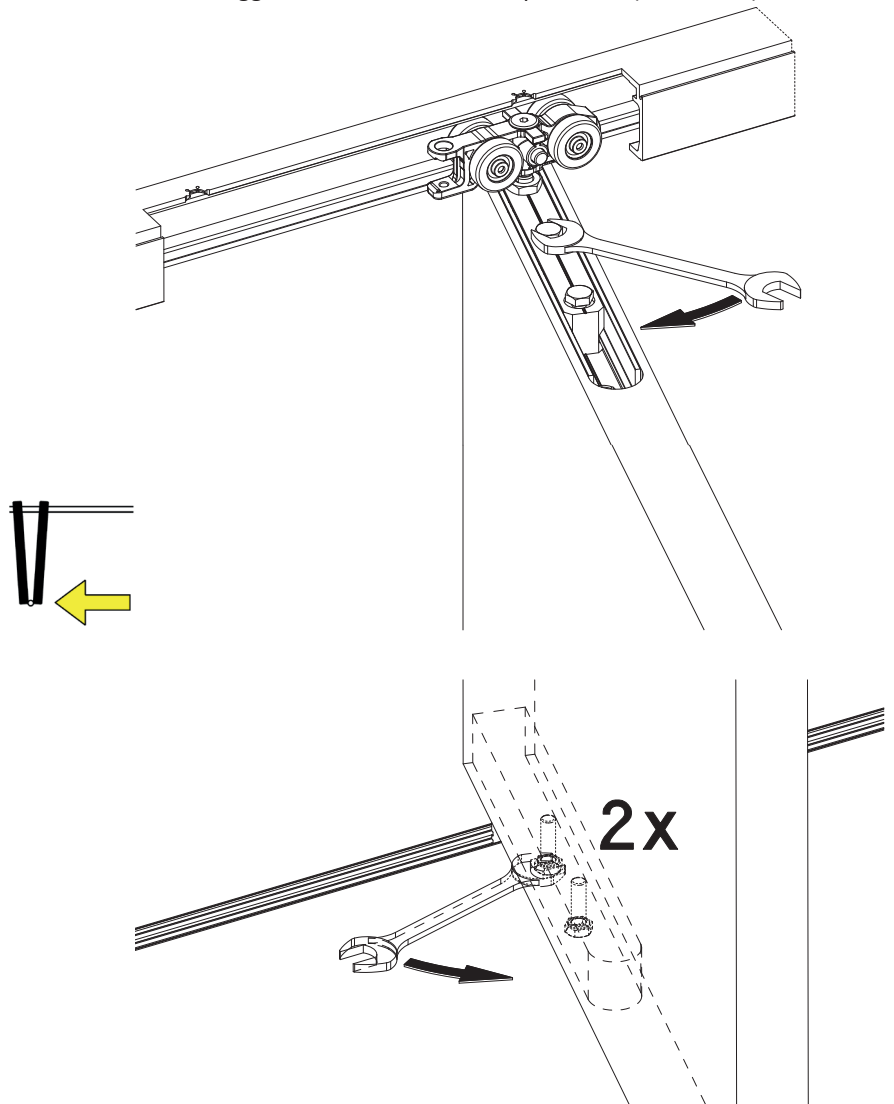

5. Inserimento a pressione Tappo

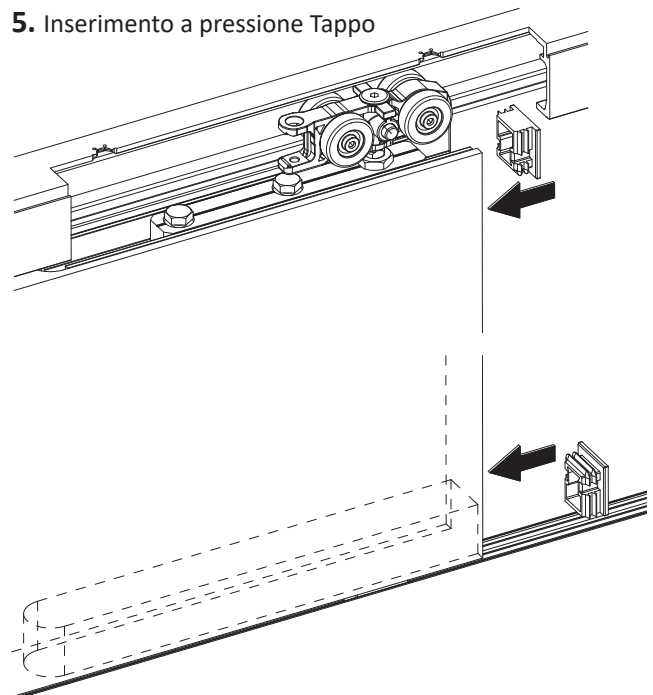





Porte Soffietto - A Baionetta

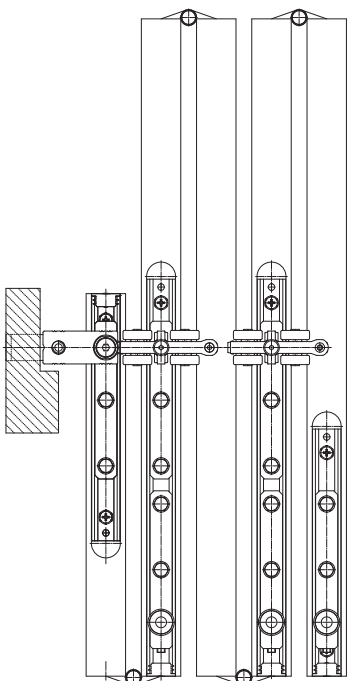



**PUMA.5320 per 2, 3, 4, 5 PORTE LEGNO SOFFIETTO - Sistema con MONTAGGIO Frontale a BAIONETTA.**

Sistema pratico di montaggio e regolazione a Baionetta, ricavato da estrusi in alluminio.

Nei KIT sono compresi i Carrelli di scorrimento, per una eventuale alternativa di questi, andare a pag.18 e 19.

- Spessore Porte : da 30 a 55 mm compresi.
- Larghezza minima Porta : 496 mm con Optional Fermo (5) - 330 mm senza Optional Fermo (5).
- Larghezza massima Porta consigliata : 900 mm - *Massima misura (LA) causa lunghezza di (11) : 1072 mm.*
- Altezza Porta : Stessa altezza delle Porte Libro, stessa minima luce superiore ed inferiore.

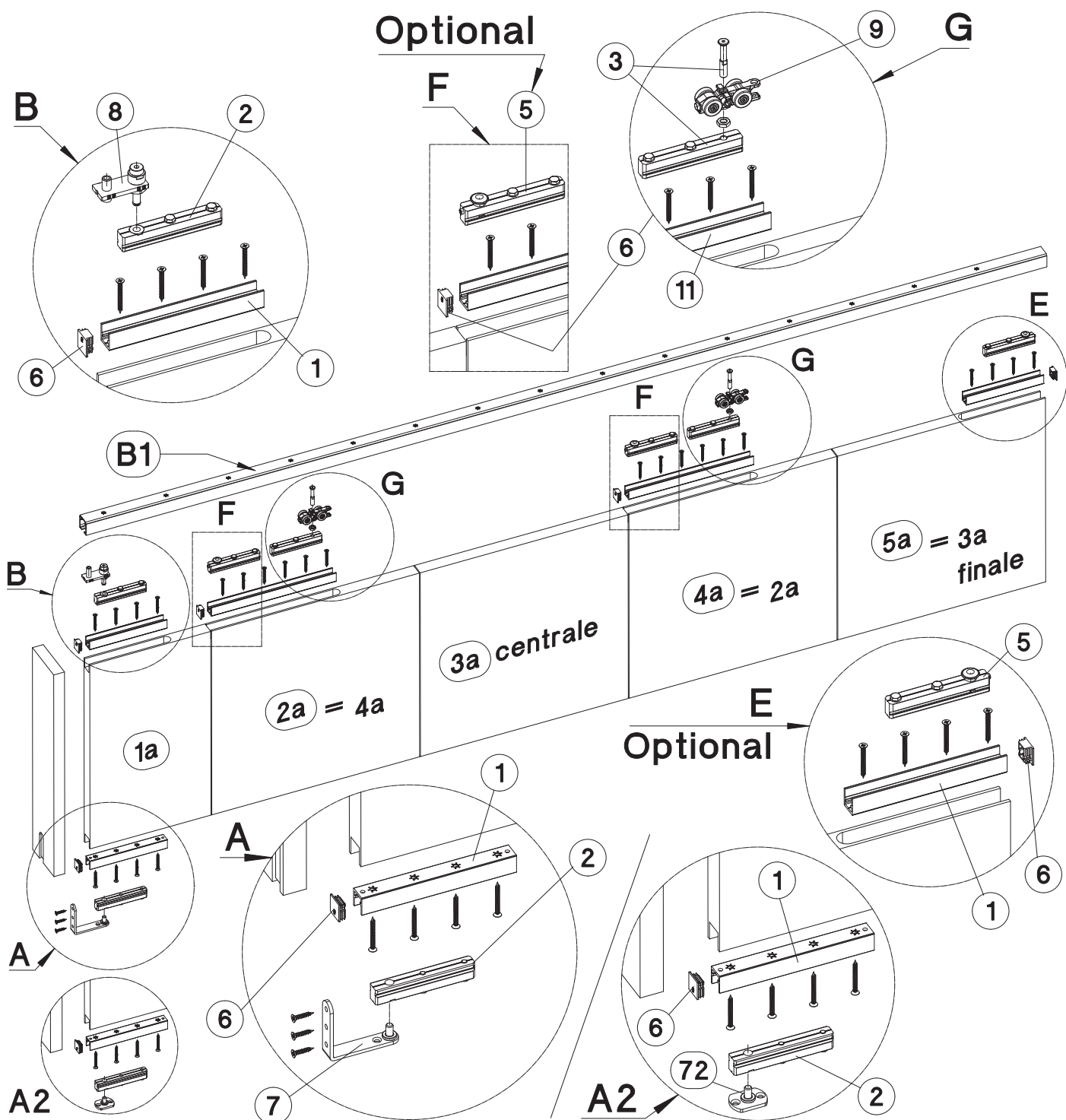
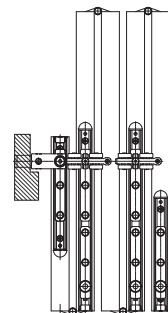



Dettaglio COMPONENTI:

Riferim.	Immagine	Codice Identificativo <u>riferito a NR.1 Pz o Kit</u> (salvo diversa indicazione)																														
(1)		Parte Fissa Baionetta L = 186 mm. - Per 1 <sup>^</sup> e 3 <sup>^</sup> o 5 <sup>^</sup> Porta Finale. Alluminio estruso, finitura Naturale. Completo di fori svasati per il fissaggio. # Codice: <b>PUMA . 5302</b>																														
(11)		Parte Fissa Baionetta L = 586 mm - <u>Da Tagliare a misura in base a (LA)</u> Alluminio estruso, finitura Naturale. Completo di fori svasati per il fissaggio. # Codice: <b>PUMA . 5304</b>																														
(2)		Parte Maschio Baionetta <u>con Bussola Foro ø 8 mm.</u> Alluminio estruso, finitura Naturale. Completo di due Viti TE M6 per il bloccaggio in posizione. # Codice: <b>PUMA . 5334 . K</b>																														
(3)		Parte Maschio Baionetta <u>con Filetto Femmina M8.</u> Alluminio estruso, finitura Naturale. Completo di: NR.2 Viti TE M6 per il bloccaggio in posizione e NR.1 Vite M8 per il collegamento al Carrello (9). # Codice: <b>PUMA . 5332 . K</b>																														
(5)		<b>OPTIONAL:</b> Parte Maschio Baionetta <u>con Fermo molleggiato M14.</u> Alluminio estruso, finitura Naturale. Completo di: NR.2 Viti TE M6 per il bloccaggio in posizione e NR.1 perno molleggiato M14 uso Fermo sotto il binario (B1) . # Codice: <b>PUMA . 5338 . K</b>																														
(6)		Tappo di chiusura di testa fresata frontale Porta per (1). Plastica morbida, diversi colori # Codice: <b>PUMA . 5932</b>																														
(7)		VERSIONE (A): Fulcro Fisso Inferiore a "L" - DX/SX <u>con Perno ø 8 mm.</u> Per fissaggio retro telaio. Acciaio. # Codice: <b>PUMA . 8030</b>																														
(72)		VERSIONE (A2): Fulcro Fisso Inferiore "Piatto", <u>con Perno ø 8 mm.</u> Per <b>fissaggio al Pavimento.</b> Acciaio. # Codice: <b>PUMA . 8032</b>																														
(8)		Fulcro Superiore DX/SX <u>con Perno ø 8 mm.</u> Posizione Regolabile. Acciaio. # Codice: <b>PUMA . 8180</b>																														
(9)		Carrello <b>Dragon Kg 140</b> (riferito a nr. 2 Carrelli) Corpo in Tecnopolimero DRAGON ( <i>esclusivo materiale SLIDING</i> ). <b>Con nr.4 Cuscinetti rettificati</b> a carrello, rivestiti in Delrin. # Codice: <b>PUMA . 6 . 2140</b>																														
(B1)		<table border="1"> <thead> <tr> <th>Binario singolo Max.240 Kg</th> <th>L [mm]</th> <th>Anodizzato Argento</th> </tr> </thead> <tbody> <tr> <td>Foratura a passo (150 mm)</td> <td>2000</td> <td>PUMA . 0101 . 2000 . A</td> </tr> <tr> <td>Foratura a passo (150 mm)</td> <td>2500</td> <td>PUMA . 0101 . 2500 . A</td> </tr> <tr> <td>Foratura a passo (150 mm)</td> <td>3000</td> <td>PUMA . 0101 . 3000 . A</td> </tr> <tr> <td>Foratura a passo (150 mm)</td> <td>6000</td> <td>PUMA . 0101 . 6000 . A</td> </tr> <tr> <th>Binario singolo Max.120 Kg</th> <th>L [mm]</th> <th>Alluminio Naturale</th> </tr> <tr> <td>Foratura a passo (150 mm)</td> <td>2000</td> <td>PUMA . 0151 . 2000 . Z</td> </tr> <tr> <td>Foratura a passo (150 mm)</td> <td>2500</td> <td>PUMA . 0151 . 2500 . Z</td> </tr> <tr> <td>Foratura a passo (150 mm)</td> <td>3000</td> <td>PUMA . 0151 . 3000 . Z</td> </tr> <tr> <td>Foratura a passo (150 mm)</td> <td>6000</td> <td>PUMA . 0151 . 6000 . Z</td> </tr> </tbody> </table>	Binario singolo Max.240 Kg	L [mm]	Anodizzato Argento	Foratura a passo (150 mm)	2000	PUMA . 0101 . 2000 . A	Foratura a passo (150 mm)	2500	PUMA . 0101 . 2500 . A	Foratura a passo (150 mm)	3000	PUMA . 0101 . 3000 . A	Foratura a passo (150 mm)	6000	PUMA . 0101 . 6000 . A	Binario singolo Max.120 Kg	L [mm]	Alluminio Naturale	Foratura a passo (150 mm)	2000	PUMA . 0151 . 2000 . Z	Foratura a passo (150 mm)	2500	PUMA . 0151 . 2500 . Z	Foratura a passo (150 mm)	3000	PUMA . 0151 . 3000 . Z	Foratura a passo (150 mm)	6000	PUMA . 0151 . 6000 . Z
Binario singolo Max.240 Kg	L [mm]	Anodizzato Argento																														
Foratura a passo (150 mm)	2000	PUMA . 0101 . 2000 . A																														
Foratura a passo (150 mm)	2500	PUMA . 0101 . 2500 . A																														
Foratura a passo (150 mm)	3000	PUMA . 0101 . 3000 . A																														
Foratura a passo (150 mm)	6000	PUMA . 0101 . 6000 . A																														
Binario singolo Max.120 Kg	L [mm]	Alluminio Naturale																														
Foratura a passo (150 mm)	2000	PUMA . 0151 . 2000 . Z																														
Foratura a passo (150 mm)	2500	PUMA . 0151 . 2500 . Z																														
Foratura a passo (150 mm)	3000	PUMA . 0151 . 3000 . Z																														
Foratura a passo (150 mm)	6000	PUMA . 0151 . 6000 . Z																														

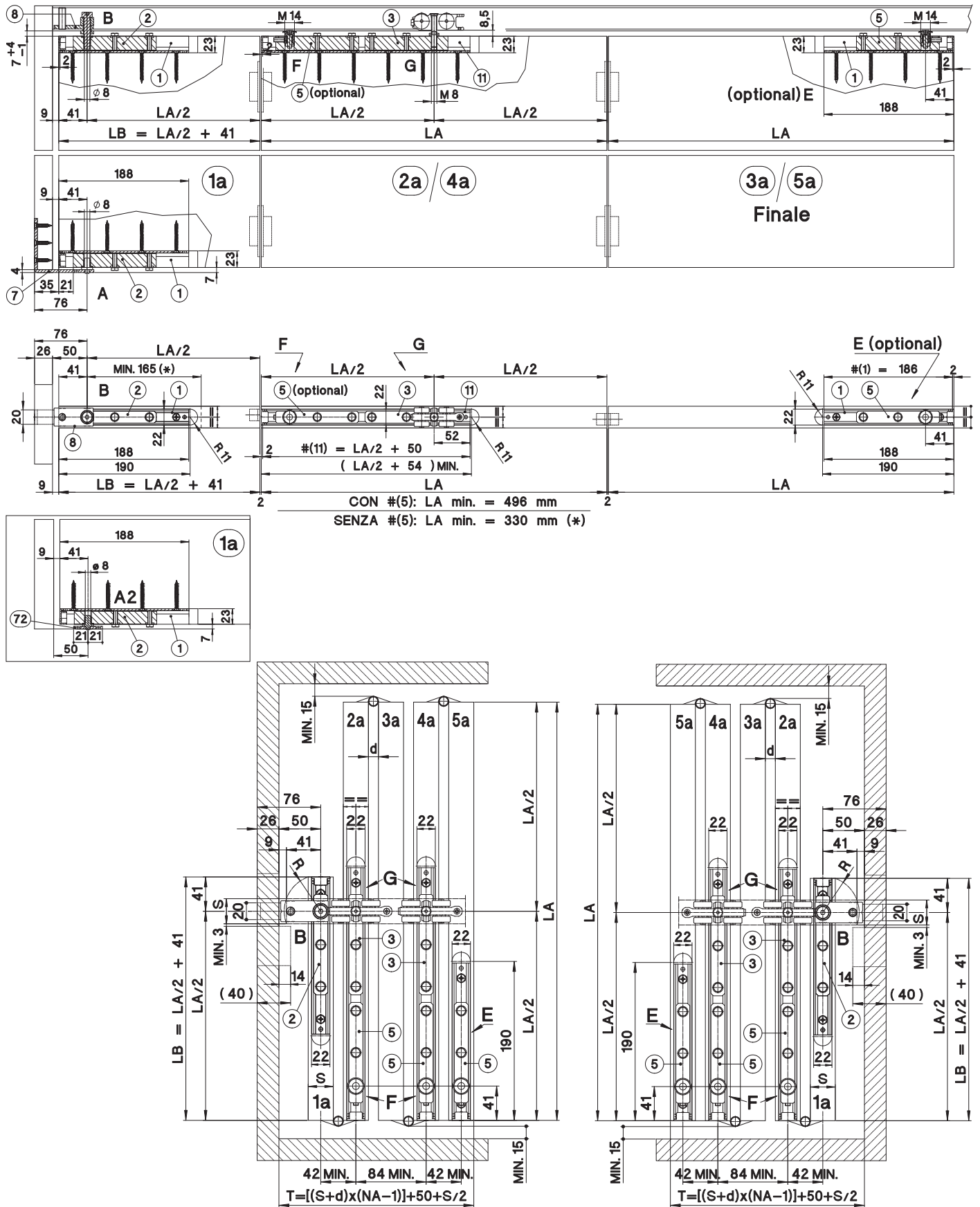

LEGENDA FORMULE / SCHEMI :	
LA	= Larghezza Porta (Anta).
LB	= Larghezza Porta Prima.
LV	= Larghezza Vano.
HA	= Altezza Porta (Anta).

HV	= Altezza Vano.
HP	= Altezza Passaggio.
NA	= Numero Porte (Ante).
1a...	= Porta (Anta) n° 1,2,3,4,5

L	= Luce Fuga.
S	= Spessore Porta (Anta).

Spessore Porta (S)  
Da 30 a 55 mm

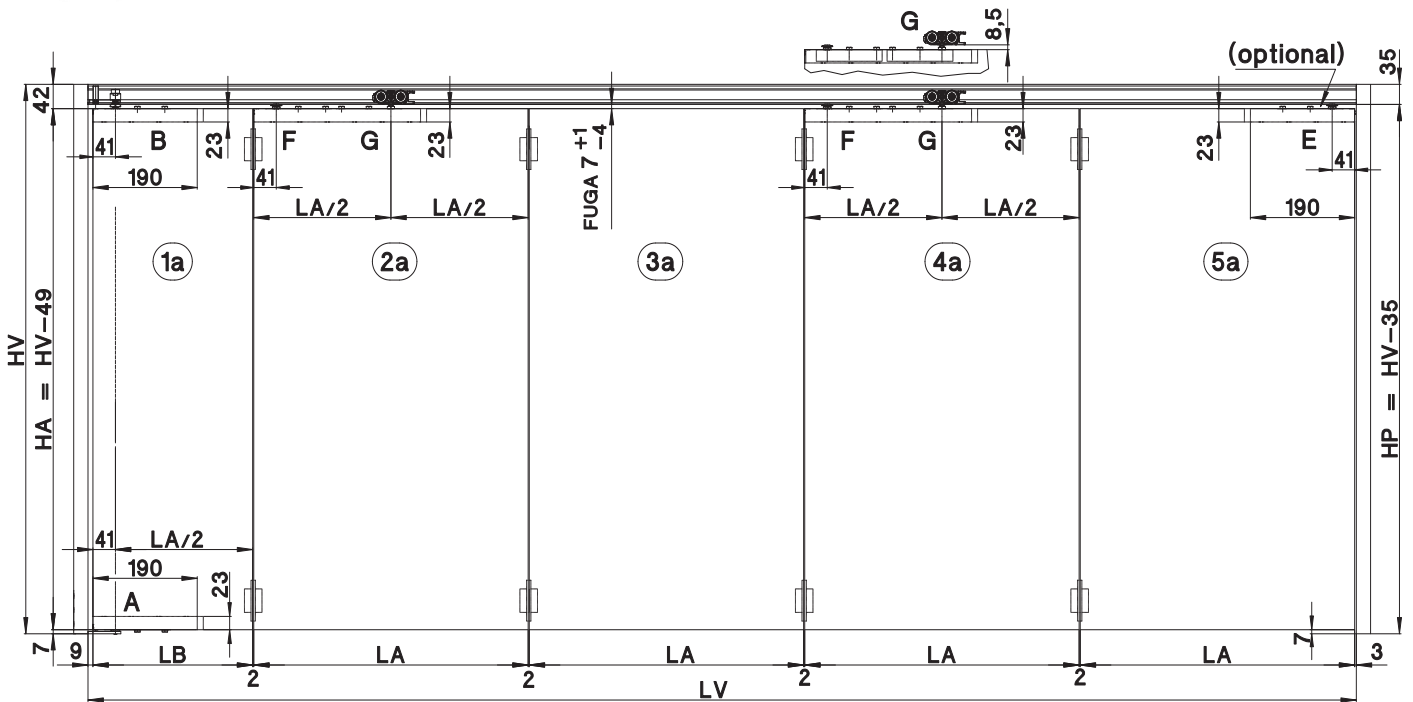

LEGENDA FORMULE / SCHEMI :

LA	= Larghezza Porta (Anta).
LB	= Larghezza Porta Prima.
LV	= Larghezza Vano.
HA	= Altezza Porta (Anta).
HV	= Altezza Vano.
HP	= Altezza Passaggio.
NA	= Numero Porte (Ante).
1a...	= Porta (Anta) n° 1,2,3,4,5
L	= Luce Fuga.
S	= Spessore Porta (Anta).

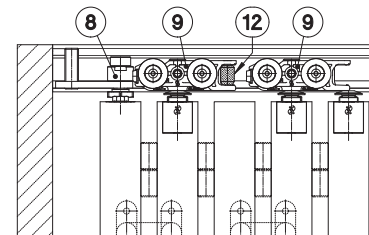

(12) Fermo da aggiungere in testa al primo Carrello (9) in caso di 4 o 5 Porte.  
# PUMA. 2590

Con Binario esterno a vista.  
Per Binario Incassato e per Carton Gesso, vedere schemi nelle pagine seguenti, dopo le Tabelle dei KIT.

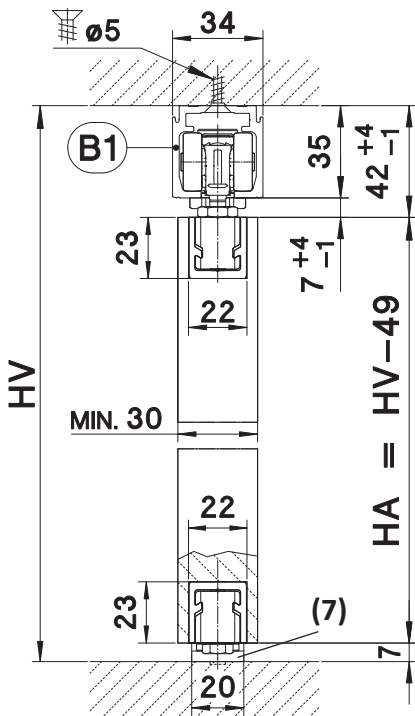

Spessore Porta (S)  
Da 30 a 55 mm

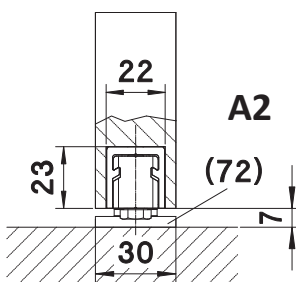

Imputare i dati nella tabella per poi calcolare LA, LB e HA.

LV =	
NA =	
HV =	

LA =	$\frac{LV - [53 + 2 \times (NA-1)]}{(NA - 0,5)}$	
LB =	$(LA/2) + 41$	
HA =	$HV - 49$	
LV =	$[LA \times (NA-1)] + LB + 12 + [(NA-1) \times 2]$	



Esempi di composizioni

SX

DX

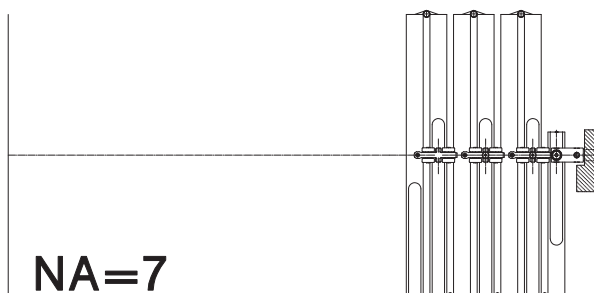
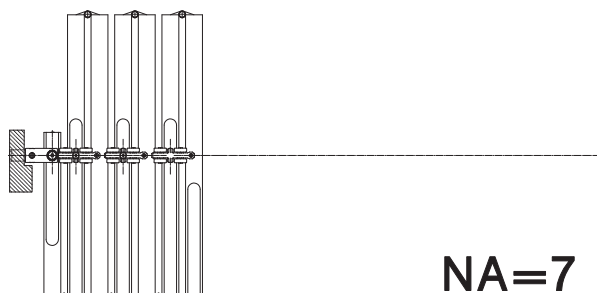
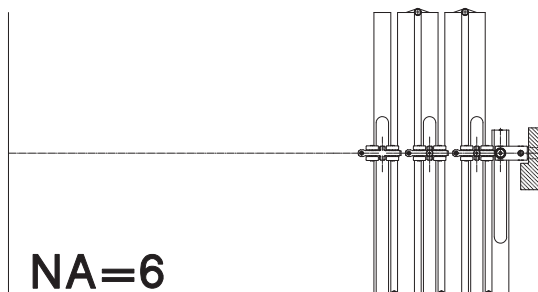
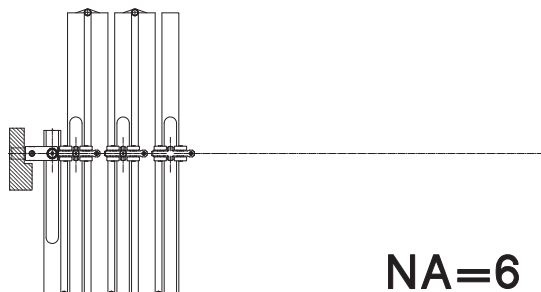
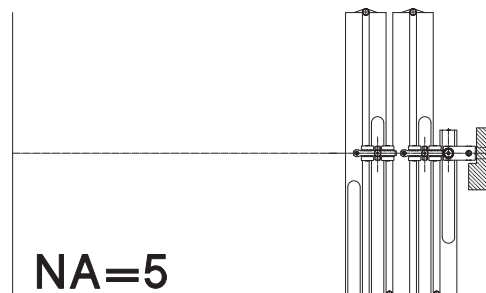
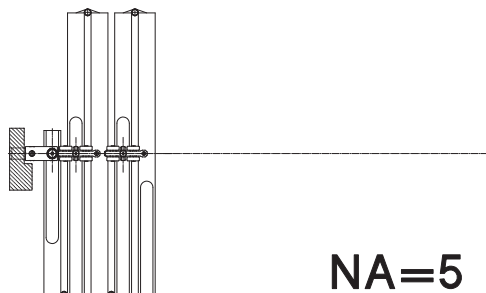
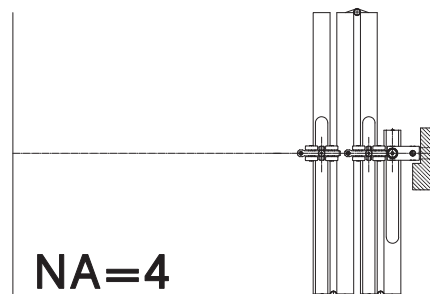
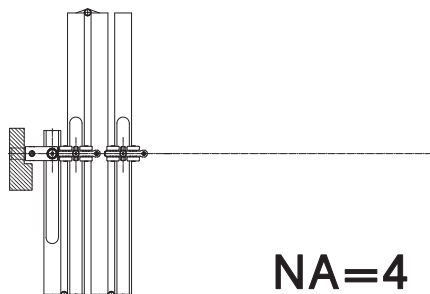
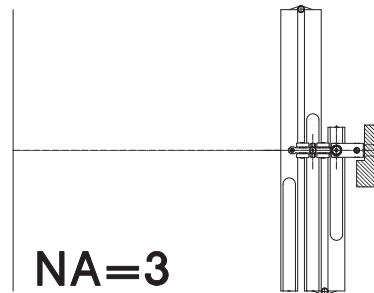
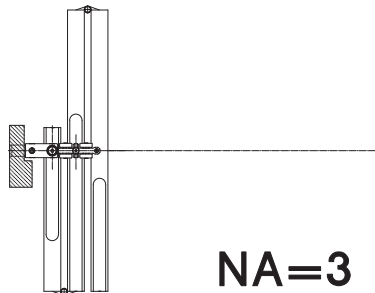
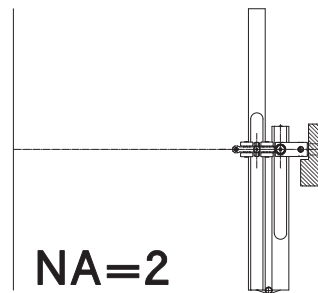
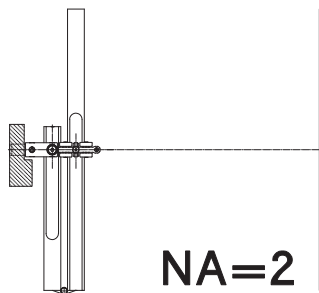

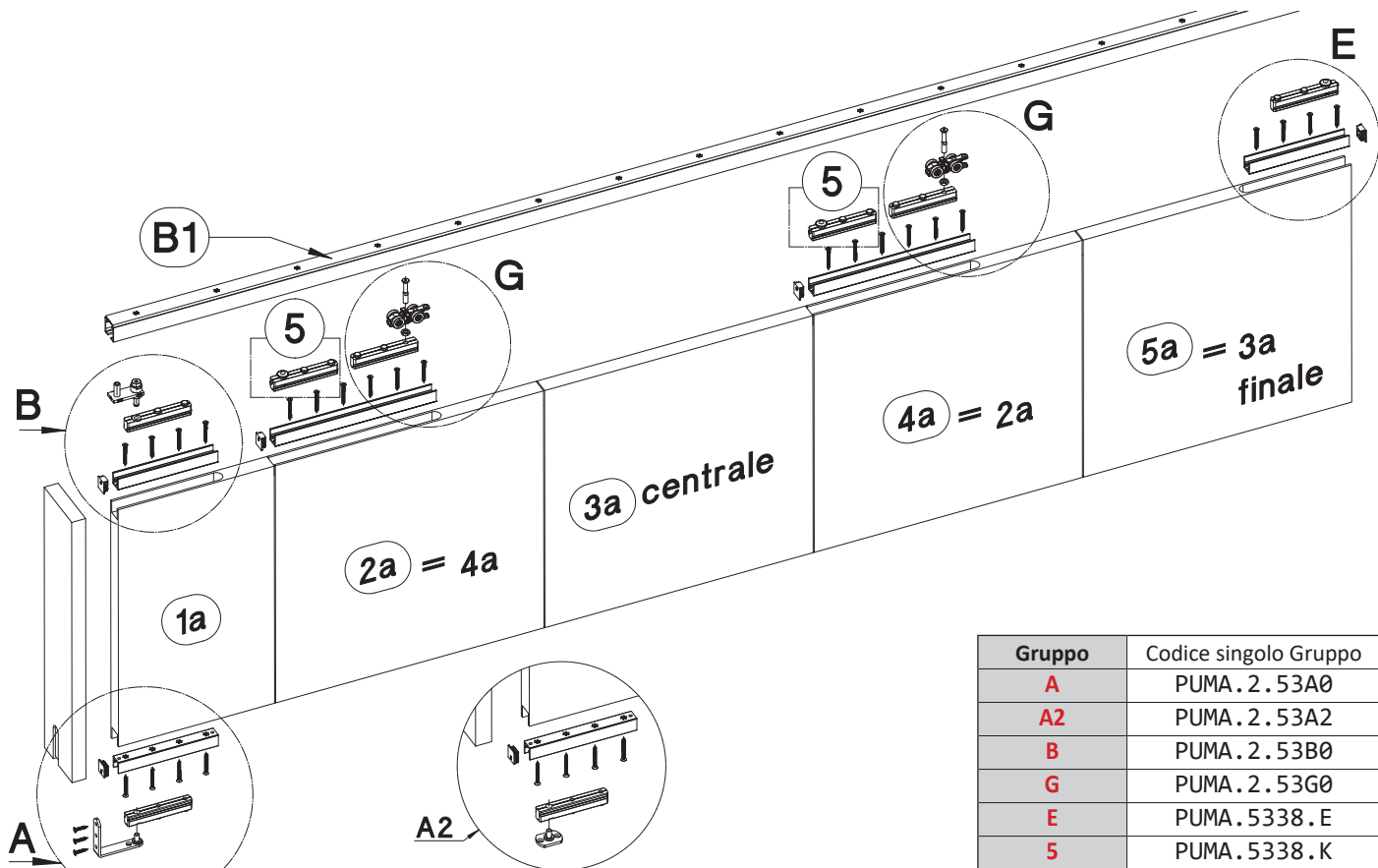

Gruppo	Codice singolo Gruppo
<b>A</b>	PUMA . 2 . 53A0
<b>A2</b>	PUMA . 2 . 53A2
<b>B</b>	PUMA . 2 . 53B0
<b>G</b>	PUMA . 2 . 53G0
<b>E</b>	PUMA . 5338 . E
<b>5</b>	PUMA . 5338 . K

TABELLA KIT "PUMA.5320" SX o DX, con Fulcro Inferiore "A", con riferim. q.tà gruppi:

Con Fulcro Inferiore a "L"

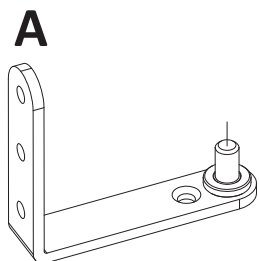

NA	RIF. KIT	Codice KIT	Rif.	Q.tà	Rif.	Q.tà	Rif.	Q.tà
2	SX o DX	PUMA . 1 . 5320 . 2030 . N	(A)	1	(B)	1	(G)	1
3	SX o DX	PUMA . 1 . 5320 . 2030 . N	(A)	1	(B)	1	(G)	1
4	SX o DX	PUMA . 1 . 5320 . 4050 . N	(A)	1	(B)	1	(G)	2
5	SX o DX	PUMA . 1 . 5320 . 4050 . N	(A)	1	(B)	1	(G)	2
6	SX o DX	PUMA . 1 . 5320 . 6070 . N	(A)	1	(B)	1	(G)	3
7	SX o DX	PUMA . 1 . 5320 . 6070 . N	(A)	1	(B)	1	(G)	3
8	SX o DX	PUMA . 1 . 5320 . 8090 . N	(A)	1	(B)	1	(G)	4
9	SX o DX	PUMA . 1 . 5320 . 8090 . N	(A)	1	(B)	1	(G)	4
10	SX o DX	PUMA . 1 . 5320 . 9091 . N	(A)	1	(B)	1	(G)	5
11	SX o DX	PUMA . 1 . 5320 . 9091 . N	(A)	1	(B)	1	(G)	5
12	SX o DX	PUMA . 1 . 5320 . 9293 . N	(A)	1	(B)	1	(G)	6
13	SX o DX	PUMA . 1 . 5320 . 9293 . N	(A)	1	(B)	1	(G)	6

OPTIONAL :	OPTIONAL :		
PUMA . 5338 . K	PUMA . 5338 . E		
Rif.	Q.tà	Rif.	Q.tà

(5)	1	(E)	-
(5)	1	(E)	1
(5)	2	(E)	-
(5)	2	(E)	1
(5)	3	(E)	-
(5)	3	(E)	1
(5)	4	(E)	-
(5)	4	(E)	1
(5)	5	(E)	-
(5)	5	(E)	1
(5)	6	(E)	-
(5)	6	(E)	1

NA = Numero Porte (Ante).

TABELLA KIT "PUMA.5322" SX o DX, con Fulcro Inferiore "A2", con riferim. q.tà gruppi:

Con Fulcro Infer. "piatto"

**A2**

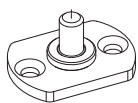

NA	RIF. KIT	Codice KIT	Rif.	Q.tà	Rif.	Q.tà	Rif.	Q.tà
2	SX o DX	PUMA . 1 . 5322 . 2030 . N	(A2)	1	(B)	1	(G)	1
3	SX o DX	PUMA . 1 . 5322 . 2030 . N	(A2)	1	(B)	1	(G)	1
4	SX o DX	PUMA . 1 . 5322 . 4050 . N	(A2)	1	(B)	1	(G)	2
5	SX o DX	PUMA . 1 . 5322 . 4050 . N	(A2)	1	(B)	1	(G)	2
6	SX o DX	PUMA . 1 . 5322 . 6070 . N	(A2)	1	(B)	1	(G)	3
7	SX o DX	PUMA . 1 . 5322 . 6070 . N	(A2)	1	(B)	1	(G)	3
8	SX o DX	PUMA . 1 . 5322 . 8090 . N	(A2)	1	(B)	1	(G)	4
9	SX o DX	PUMA . 1 . 5322 . 8090 . N	(A2)	1	(B)	1	(G)	4
10	SX o DX	PUMA . 1 . 5322 . 9091 . N	(A2)	1	(B)	1	(G)	5
11	SX o DX	PUMA . 1 . 5322 . 9091 . N	(A2)	1	(B)	1	(G)	5
12	SX o DX	PUMA . 1 . 5322 . 9293 . N	(A2)	1	(B)	1	(G)	6
13	SX o DX	PUMA . 1 . 5322 . 9293 . N	(A2)	1	(B)	1	(G)	6

OPTIONAL :	OPTIONAL :		
PUMA . 5338 . K	PUMA . 5338 . E		
Rif.	Q.tà	Rif.	Q.tà

(5)	1	(E)	-
(5)	1	(E)	1
(5)	2	(E)	-
(5)	2	(E)	1
(5)	3	(E)	-
(5)	3	(E)	1
(5)	4	(E)	-
(5)	4	(E)	1
(5)	5	(E)	-
(5)	5	(E)	1
(5)	6	(E)	-
(5)	6	(E)	1



Schemi ingombri per Binario Incassato e per applicazioni con Carton Gesso.

**Binario Incassato:**

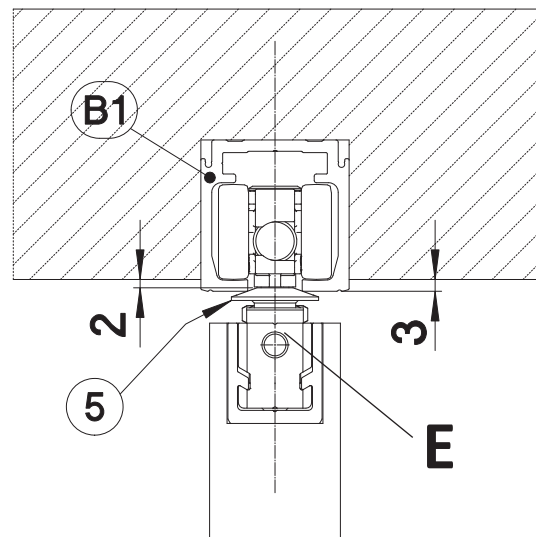
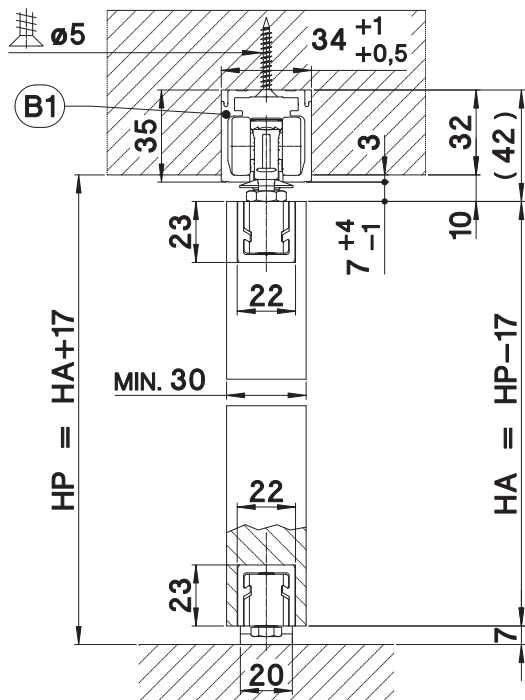

Sporgenza inferiore del Binario (B1) necessaria per il funzionamento del Fermo Molleggiato (5)

**Carton Gesso:**

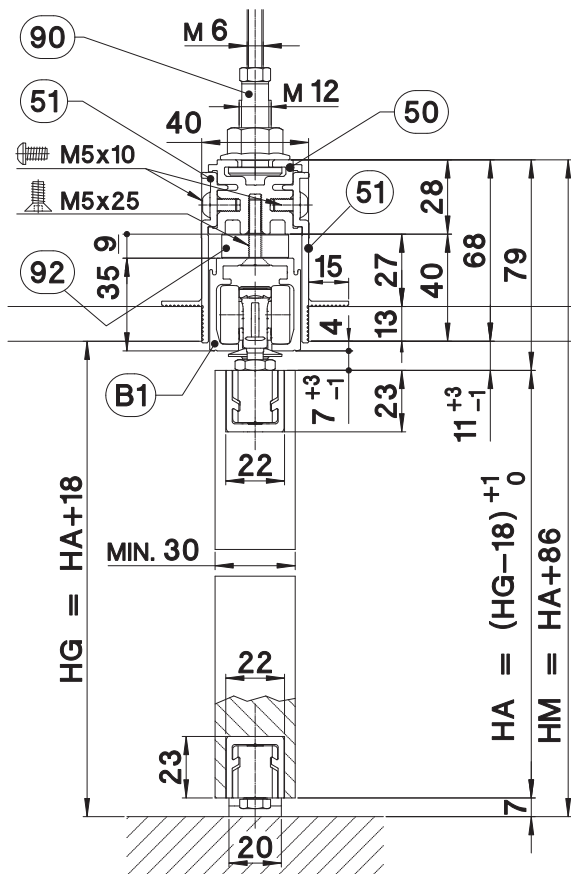

Sporgenza inferiore del Binario (B1) necessaria per il funzionamento del Fermo Molleggiato

(92) Distanziale per Binario da inserire nei profili per Carton Gesso

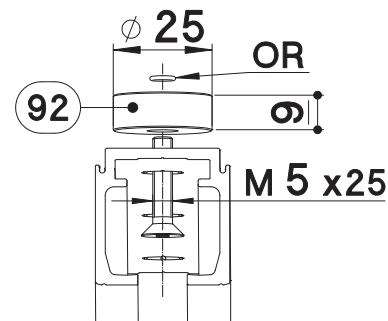

1.

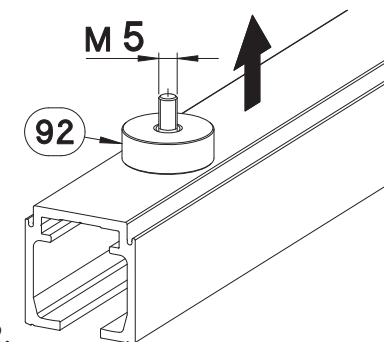

2.

Parte	Codice per NR.1 Kit : distaziale + vite + Or
(92)	PUMA.1930.K

Prevedere NR.1 Kit ogni 450 mm

Per i riferimenti dei profili (50) e (51), dell'accessorio (92) andare alle pagine "Composizioni Carton Gesso Legno" delle pagine del catalogo Sliding, riferimento "PUMA".